

UNISIM

Virtex 5 FXT Simulator Manual

Gilles Mouchard

Contents

1	Introduction	3
1.1	UNISIM	3
1.2	Virtex 5 FXT Simulator	3
2	Building the simulator	6
2.1	Requirements	6
2.2	Installing SystemC 2.3	6
2.2.1	Download the source code	6
2.2.2	Uncompressing the source code tarballs	6
2.2.3	Configuring SystemC	7
2.2.4	Compiling and installing SystemC	7
2.3	Building the UNISIM Virtex 5 FXT simulator	7
2.3.1	Uncompressing the source code tarball	7
2.3.2	Configuring the simulator building process	7
2.3.3	Compiling the simulator	7
3	Cross-compiling the simulator	8
3.1	Requirements	8
3.2	Installing a cross-compiled SystemC 2.3.0	8
3.2.1	Download the source code	8
3.2.2	Uncompressing the source code tarballs	8
3.2.3	Configuring SystemC	9
3.2.4	Cross-compiling and installing SystemC	9
3.3	Cross-compiling zlib	9
3.4	Cross-compiling libxml2	9
3.5	Cross-compiling Boost	9
3.6	Cross-compiling the UNISIM Virtex 5 FXT simulator	10
3.6.1	Uncompressing the source code tarball	10
3.6.2	Configuring the simulator building process	10
3.6.3	Cross-compiling the simulator	10
4	Getting started	10
4.1	Run-time configuration	10
4.2	Loading binaries	11
4.3	Serial console	12
4.4	Using the builtin debugger	12
4.5	Using a GNU crosstool chain	12
4.5.1	Building a GNU crosstool chain	12
4.5.2	Using cross-GCC	15
4.5.3	Using cross-GDB	15

5	Examples of use	15
5.1	Basic system level tests	15
5.1.1	Description	15
5.1.2	Building the tests	16
5.1.3	Running the tests	17
5.2	The MiBench version 1 benchmarks	18
5.2.1	Description	18
5.2.2	Building the benchmarks	18
5.2.3	Running the benchmarks	18
5.3	A light weight Linux distribution	20
5.3.1	The boot program	20
5.3.2	The Linux kernel	21
5.3.3	The device Tree	21
5.3.4	The initial RAM disk	24
5.3.5	Busybox	26
5.3.6	Building the distribution	26
5.3.7	Booting the distribution	26
A	Simulator technical reference (generated)	30
A.1	Introduction	30
A.2	Licensing	30
A.3	Simulated configuration	30
A.4	Using the UNISIM Virtex 5 FXT simulator	36
A.5	Configuration	36
A.6	Statistics	103
A.7	Formulas	110

List of Figures

1	UNISIM Virtex 5 FXT simulator schematic.	4
2	crosstool chain build configuration (changes from default only) for Crosstool-NG 1.18.0.	14
3	Boot program (boot.S compiled as boot.elf) loaded in BRAM.	22
4	Linux kernel configuration (changes from default only).	23
5	UNISIM Virtex 5 FXT simulator schematic.	30

List of Tables

1	Simulator memory mapping.	4
2	Summary of basic system level tests.	16
3	MiBench version 1.0.	19
4	Files for booting Linux in the simulator.	20
5	Linux kernel register parameters.	22
6	Initial RAM disks.	25

1 Introduction

1.1 UNISIM

UNISIM provides several virtual platforms and a framework to ease the development of new virtual platforms. A virtual platform is a software tool, often called simulator, that mimics the behavior of an electronic system so that software can run on it before silicon or FPGA implementation of that electronic system is available. The simulated electronic system can include lots of microprocessors and devices. Depending on the needed representativeness and simulator development budget, a simulator can be as simple as an instruction set simulator as well as a full system simulator. A full system simulator, not only executes the microprocessor instruction set, like an instruction set simulator, but also simulates buses, I/O devices, sensors, actuators, so that real application workloads and operating systems can run on them. Most of UNISIM virtual platforms are full system simulators, which means that they are sufficiently representative of the real hardware that whole operating systems (e.g. Linux, VxWorks), unmodified software stacks (e.g. an AUTOSAR software stack), and industrial applications can run on them. The UNISIM virtual platforms are modular: a simulator is the assembly of properly configured simulation components (e.g. CPU, RAM, buses). They are written in C/C++ and based on industry standards, like IEEE1666TM, Accellera SystemCTM and Accellera SystemCTM TLM 2.0.

Some use cases of UNISIM virtual platforms are:

- Development of SystemC IPs (intellectual property) and new virtual platforms: UNISIM is an open development environment that comprise a SystemC module library, and a set of services (debugging, program loaders,). It can be a foundation for the development of new SystemC IPs and new virtual virtual platforms.
- Hybrid virtual platform: UNISIM/SystemC and an FPGA accelerator can be mixed to build some hybrid virtual platforms: for instance simulating processor cores within UNISIM/SystemC, and prototyping specialized IPs/devices within an FPGA accelerator. Hybridization allows using indifferently both UNISIM/SystemC IPs (on a standard host machine) and VHDL IPs (on an FPGA accelerator), but also speeding up simulation of large systems.
- Non-intrusive debugging and testing of software: It means that, unlike on the real hardware, software can be debugged and tested without affecting either its functional and/or temporal behavior. With such virtual instrumentation, the user can seamlessly stop and resume execution of software, profile the software, inspect the system status, inject values on the sensors, modify the state of program variables and microprocessor/device registers, and then analyze the result without modifying the software.
- Hardware/software integration: software stack can be debugged and tested within a representative hardware environment before the availability of either the FPGA prototypes or the real hardware. The software stack can be composed of low level software (e.g. drivers), of a real-time operating system, and of applications generated from high level models (Papyrus, Matlab Simulink, Statemate Stateflow,)

Several open source virtual platforms for different targets (ARM, PowerPC, Star12X, and TMS320C3X) and different hosts (Linux, Windows, Mac OS X) are available for download here. These virtual platforms have been evaluated and used in various industry domains such as automotive, avionic, military, electrical equipments for medium tension, nuclear safety.

1.2 Virtex 5 FXT Simulator

The UNISIM Virtex 5 FXT is a virtual platform that tries to mimic a Xilinx ML507 development board that include a Xilinx Virtex 5 FXT (FPGA + PPC440).

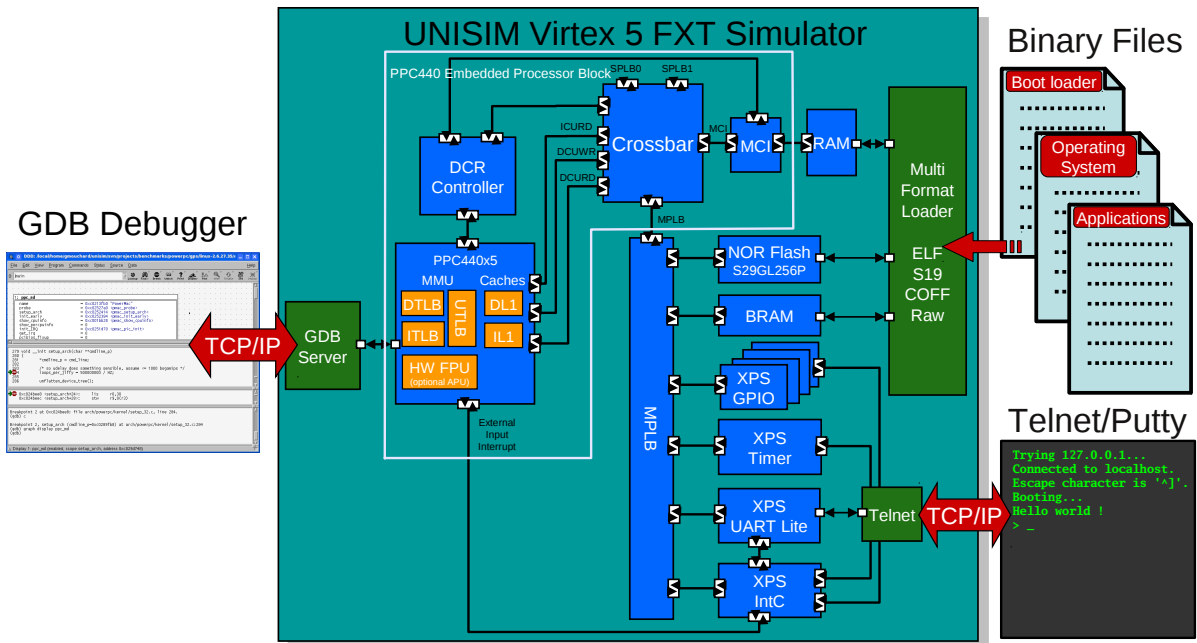

Figure 1: UNISIM Virtex 5 FXT simulator schematic.

Address range	Component name	Hardware device
0x00000000-0x0003ffff	ram	256 MB RAM
0x81400000-0x8140ffff	gpio-leds-8bit	XPS GPIO
0x81420000-0x8142ffff	gpio-5-leds-positions	XPS GPIO
0x81440000-0x8144ffff	gpio-push-buttons-5bit	XPS GPIO
0x81460000-0x8146ffff	gpio-dip-switches-8bit	XPS GPIO
0x81800000-0x8180ffff	intc	XPS IntC
0x83c00000-0x83c0ffff	timer	XPS Timer/Counter
0x84000000-0x8400ffff	uart-lite	XPS UART Lite
0xfc000000-0xfdffffff	flash	S29GL256P
0xfffc0000-0xffffffff	bram	256 KB BRAM

Table 1: Simulator memory mapping.

The UNISIM Virtex 5 FXT simulator, which Figure 1 shows the schematic, implements the following:

- PPC440 Embedded Processor Block (UG200 [9]):
 - All the PPC440x5 [4] instruction set of a Xilinx Virtex 5 FXT
 - Optional FPU that is similar to Xilinx FPU APU [12]
 - PowerPC Book E MMU (shadow ITLB, shadow DTLB, unified TLB)
 - Caches (instruction and data)
 - Integrated timers (decrementer, fixed interval, watchdog)
 - Exception handling mechanisms
 - DCR (device control register) bus controller
 - Crossbar
 - MCI (Memory Controller Interface)
 - MPLB (master processor local bus) interface
 - SPLB0 and SPLB1 (slave processor local bus) interfaces
- MPLB (master processor local bus) link
- 256 MB RAM on MCI
- 256 KB BRAM on MPLB
- XPS IntC interrupt controller (v2.01a) [10] on MPLB
- XPS Timer/Counter (v1.02a) [11] on MPLB
- Spansion 256 Mbits (32 MB) S29GL256P off-chip flash memory [6] on MPLB
- XPS UART Lite (v1.01a) [8] on MPLB
- Four XPS GPIO modules (v2.00a) [7] on MPLB connected to two LED boards and two DIP switch/push buttons boards

Several stub modules are currently integrated in the simulator to test the XPS Timer/Counter module:

- GenerateOut stubs connected on XPS Timer/Counter GenerateOut outputs
- PWM stub connected on XPS Timer/Counter PWM0 output
- CaptureTrigger stubs (optional randomized outputs) connected on XPS Timer/Counter CaptureTrigger inputs
- SPLB stubs
- DCR stubs

The simulator also supports the following features:

- Loading of ELF32, ELF64 [3] and Motorola S19 (S-Record) [2] files
- An integrated console debugger that supports debugging both at assembly level and source level (e.g. C source code). Source level debugging is only available for ELF binary files including DWARF v2 or v3 [5] debugging informations
- Support for the GDB [14] serial remote protocol over TCP/IP. That allows debugging a binary running into the simulator at assembly and/or source level using the GNU debugger (aka GDB)
- Support for a telnet console over the XPS UART Lite

Table 1 shows the simulator memory mapping.

The 1.0 release of the simulator is composed of:

- the simulator source code: `unisim-virtex5fxt-1.0beta11.tar.gz`
- the present documentation

Please follow the installation instructions in Section 2 to get the simulator building on your own building environment. Section 4 presents the basics for using the simulator. Section 5 presents some examples of use of the simulator. Appendix A contains the technical references (generated) of the simulator.

2 Building the simulator

2.1 Requirements

The following tools or libraries must be installed:

- GNU C++ compiler (aka. `g++`)
- GNU Flex (aka. `flex`)
- GNU Bison (aka. `bison`)
- Standard GNU C++ library (aka. `libstdc++-dev` that comes with `g++`)
- Boost (aka. `libboost-dev`)
- Editline/Libedit (aka. `libedit-dev`)
- zlib (aka. `zlib1g-dev`)
- libxml2 (aka. `libxml2-dev`)

2.2 Installing SystemC 2.3

2.2.1 Download the source code

Register at <http://www.accelera.org> and then download `systemc-2.3.0.tgz` from the Accelera SystemC standards download page.

2.2.2 Uncompressing the source code tarballs

```
$ tar zxvf systemc-2.3.0.tgz
```

This will uncompress the source of SystemC in directory `systemc-2.3.0`.

2.2.3 Configuring SystemC

To handle threads, SystemC relies on QuickThreads, a fast implementation of user's threads. QuickThreads speeds-up threads switching compared to the slower kernel POSIX threads and thus considerably improves overall simulation performance. To configure the SystemC building process with the built-in QuickThreads (recommended), do the following at the command prompt:

```
$ cd systemc-2.3.0
$ mkdir objdir
$ cd objdir
$ mkdir ${HOME}/systemc
$ ../configure --prefix=${HOME}/systemc --disable-shared
```

However, if you intend to instrument your simulator (e.g. with valgrind) to debug the simulator memory leaks, bad memory accesses, pointers, and uninitialized memory reads, you should use the slower kernel POSIX threads. To configure the SystemC building process with the kernel POSIX threads, do the following at the command prompt:

```
$ cd systemc-2.3.0
$ mkdir objdir
$ cd objdir
$ mkdir ${HOME}/systemc
$ ../configure --prefix=${HOME}/systemc --enable-pthreads --disable-shared
```

2.2.4 Compiling and installing SystemC

To compile SystemC, do the following at the command prompt:

```
$ make
$ make install
```

2.3 Building the UNISIM Virtex 5 FXT simulator

2.3.1 Uncompressing the source code tarball

```
$ tar zxvf unisim-virtex5fxt-1.0beta11.tar.gz
```

2.3.2 Configuring the simulator building process

```
$ cd unisim-virtex5fxt-1.0beta11
$ ./configure \
    --with-systemc=${HOME}/systemc
```

2.3.3 Compiling the simulator

```
$ make
```

The simulator binaries are in `virtex5fxt/bin` subdirectory. The simulators comes in eight flavors in:

- `unisim-virtex5fxt-1.0beta11`: release simulator
- `unisim-virtex5fxt-wfpu-1.0beta11`: release simulator with a FPU APU
- `unisim-virtex5fxt-wfpu-wocache-1.0beta11`: release simulator with a FPU APU but without instruction and data caches
- `unisim-virtex5fxt-wocache-1.0beta11`: release simulator without instruction and data caches

- `unisim-virtex5fxt-debug-1.0beta11`: development simulator
- `unisim-virtex5fxt-wfpu-debug-1.0beta11`: development simulator with a FPU APU
- `unisim-virtex5fxt-wfpu-wocache-debug-1.0beta11`: development simulator with a FPU APU but without instruction and data caches
- `unisim-virtex5fxt-wocache-debug-1.0beta11`: development simulator without instruction and data caches

3 Cross-compiling the simulator

This section explains how to build (i.e. cross-compile) the simulator for a host system type (e.g. Windows) from another build system type (e.g. Linux/i386). The simulator is built on the build machine whereas it will run on the host machine. In later sub-sections, we consider cross-compiling the simulator for Windows from a Linux distribution using the mingw32 GCC cross-compiler. Most Linux distributions provide a mingw32 tool chain as a set of packages. Once installed the mingw32 tool chain binary file names are prefixed with:

- `i586-mingw32msvc-` on Ubuntu and Debian Linux distributions
- `i686-pc-mingw32-` on RedHat, Fedora, and SUSE Linux distributions
- `i586-pc-mingw32-` on Mandriva and Mageia Linux distributions

The later sub-sections will refer to the mingw32 tool chain of Ubuntu and Debian Linux distributions.

3.1 Requirements

The following tools must be installed on the Linux build system:

- GNU C++ cross-compiler for the host system type (aka. `i586-mingw32msvc-g++`)
- GNU Flex (aka. `flex`)
- GNU Bison (aka. `bison`)
- Standard GNU C++ library for the host machine (aka. `libstdc++`)

3.2 Installing a cross-compiled SystemC 2.3.0

3.2.1 Download the source code

Register at <http://www.accellera.org> and then download `systemc-2.3.0.tgz` from the Accellera SystemC standards download page.

3.2.2 Uncompressing the source code tarballs

```
$ tar zxvf systemc-2.3.0.tgz
```

This will uncompress the source of SystemC in directory `systemc-2.3.0`.

3.2.3 Configuring SystemC

To configure, cross-compile, and install SystemC in your home directory, do the following at the command prompt:

```
$ cd systemc-2.3.0
$ mkdir objdir
$ cd objdir
$ mkdir ${HOME}/systemc-mingw32
$ ../configure --prefix=${HOME}/systemc-mingw32 --host=i586-mingw32msvc --disable-shared
```

3.2.4 Cross-compiling and installing SystemC

To cross-compile SystemC, do the following at the command prompt:

```
$ make
$ make install
```

3.3 Cross-compiling zlib

Download the source code tarball at <http://zlib.net/zlib-1.2.5.tar.gz>. Uncompress the source code tarball and cross-compile the library:

```
$ tar zxvf zlib-1.2.5.tar.gz
$ cd zlib-1.2.5
$ mkdir ${HOME}/zlib-mingw32
$ make -f win32/Makefile.gcc \
  PREFIX=i586-mingw32msvc- \
  BINARY_PATH=${HOME}/zlib-mingw32/bin \
  INCLUDE_PATH=${HOME}/zlib-mingw32/include \
  LIBRARY_PATH=${HOME}/zlib-mingw32/lib \
  SHARED_MODE=1 install
$ mv ${HOME}/zlib-mingw32/bin/zdll.a ${HOME}/zlib-mingw32/bin/z.dll.a
```

3.4 Cross-compiling libxml2

Download the source code tarball at <ftp://xmlsoft.org/libxml2/libxml2-2.7.8.tar.gz>. Uncompress the source code tarball and cross-compile the library:

```
$ tar zxvf libxml2-2.7.8.tar.gz
$ cd libxml2-2.7.8
$ mkdir ${HOME}/libxml2-mingw32
$ ./configure --host=i586-mingw32msvc \
  --without-python --with-zlib=${HOME}/zlib-mingw32 \
  CPPFLAGS='-DLIBXML_STATIC'
$ make
$ make install prefix=${HOME}/libxml2-mingw32
```

3.5 Cross-compiling Boost

Download the source code tarball at http://downloads.sourceforge.net/boost/boost_1_47_0.tar.bz2. Uncompress the source code tarball and cross-compile the library:

```
$ tar jxvf boost_1_47_0.tar.bz2
$ cd boost_1_47_0
$ mkdir ${HOME}/boost-mingw32
$ ./bootstrap.sh --without-icu
$ MINGW32_VERSION=$(i586-mingw32msvc-g++ -v 2>&1 | tail -1 | awk '{print $3}' | cut -f 1 -d '-')
$ echo "using gcc : ${MINGW32_VERSION} :
  i586-mingw32msvc-g++ :
  <rc>i586-mingw32msvc-windres
```

```

        <archiver>i586-mingw32msvc-ar
    ;" > user-config.jam
$ ./bjam toolset=gcc target-os=windows variant=release threading=multi threadapi=win32 \
  link=shared runtime-link=shared --prefix=${HOME}/boost-mingw32 --user-config=user-config.jam \
  --without-mpi --without-python -sNO_BZIP2=1 -sZLIB_BINARY=z.dll \
  -sZLIB_INCLUDE=${HOME}/zlib-mingw32/include -sZLIB_LIBPATH=${HOME}/zlib-mingw32/lib \
  --layout=tagged install

```

3.6 Cross-compiling the UNISIM Virtex 5 FXT simulator

3.6.1 Uncompressing the source code tarball

```
$ tar xzvf unisim-virtex5fxt-1.0beta11.tar.gz
```

3.6.2 Configuring the simulator building process

```

$ cd unisim-virtex5fxt-1.0beta11
$ ./configure.cross \
  --host=i586-mingw32msvc \
  --with-systemc=${HOME}/systemc-mingw32 \
  --with-zlib=${HOME}/zlib-mingw32 \
  --with-libxml2=${HOME}/libxml2-mingw32 \
  --with-boost=${HOME}/boost-mingw32 \
  CXXFLAGS='-O3 -g3 -Wall'

```

3.6.3 Cross-compiling the simulator

```
$ make -f Makefile.cross
```

The simulator binaries are in `virtex5fxt/bin` subdirectory. The simulators comes in four flavors in:

- `unisim-virtex5fxt-1.0beta11.exe`: release simulator without FPU
- `unisim-virtex5fxt-wfpu-1.0beta11.exe`: release simulator with FPU
- `unisim-virtex5fxt-debug-1.0beta11.exe`: developement simulator
- `unisim-virtex5fxt-wfpu-debug-1.0beta11.exe`: developement simulator with FPU

The simulator binaries may need some DLLs from mingw32 (e.g. `libgcc_s*.dll`) or third party libraries (e.g. `libxml2-2.dll`). Place these DLLs in the `virtex5fxt/bin` subdirectory. If you prefer not to use DLLs, add `LDLAGS=-static` to the `configure.cross` command line arguments. The simulator binaries can run natively run on a Windows host system, or an emulated Windows using `wine` windows emulator.

4 Getting started

In this section, we present the basics for using the simulator. More details are available in Appendix A.

4.1 Run-time configuration

The simulator has a parametrization system that allows configuring individual simulator components, that is the hardware components, and the services. The simulator stores its configuration (a set of parameters) in a XML configuration file.

The simulator can provide the user with a default XML configuration file with option `-g`:

```
$ unisim-virtex5fxt-wfpu-1.0beta11 -g default_sim_config.xml
```

The XML configuration file can be edited, and then reloaded by the simulator with option `-c`:

```
$ unisim-virtex5fxt-wfpu-1.0beta11 -c sim_config.xml
```

The user can also simply set the value of an individual parameter with option `-s`:

```
$ unisim-virtex5fxt-wfpu-1.0beta11 -s enable-inline-debugger=true
```

The simulator can print the list of parameter set on the console with option `-l`:

```
$ unisim-virtex5fxt-wfpu-1.0beta11 -l
```

In general, each simulator components have log messages that can be switched on or off using a parameter named `verbose` (or approaching):

```
$ unisim-virtex5fxt-wfpu-1.0beta11 -s cpu.verbose-exception=true
```

The simulator accepts any combination of the above options. For example, you can combine these options to change the value of one or more parameters in an XML configuration file:

```
$ unisim-virtex5fxt-wfpu-1.0beta11 -c sim_config.xml -s enable-inline-debugger=true -g sim_config.xml
```

4.2 Loading binaries

The simulators has a multi-format loader service that can detect the format of binaries and accordingly instantiate the right loader. The user can set the list of binary files to load in Parameter `loader.filename`, each filenames being separated by a comma:

```
$ unisim-virtex5fxt-wfpu-1.0beta11 -s loader.filename='boot.elf,vmlinux,device_tree.dtb,initrd.img'
```

In the hypothetical case where the multi-format loader would wrongly guess the format of a binary, the user tells the loader what is the format of the binary file:

```
$ unisim-virtex5fxt-wfpu-1.0beta11 \  
-s loader.filename='boot.elf:elf32,vmlinux:elf32,device_tree.dtb:raw,initrd.img:raw'
```

If, for any reason (virtual memory, self relocation), the simulator must load a binary file to an address that is not the final address indicated in the binary file itself, the user tells the loader to override (when possible) the base address:

```
$ unisim-virtex5fxt-wfpu-1.0beta11 \  
-s loader.filename='boot.elf,vmlinux,device_tree.dtb,initrd.img' \  
-s loader.file1.base-addr=0 \  
-s loader.file1.force-base-addr=true
```

If you intend to do "Linux User mode" simulation, that is running a statically linked application binary designed for Linux/PPC440 without actually running Linux/PPC440 within the simulator, as opposed to "full system simulation", you should enable Linux system call translation using command line option `--enable-linux-os=1`.

4.3 Serial console

The simulator comes with a UART Lite module on MPLB that the target application can use as a serial console. The simulator telnet service, that is actually a server for the telnet protocol, manages communication between the real network and the virtual UART Lite module. The combination of the UART Lite module, the telnet service and a serial console aware target application, enables using a real telnet client (running on the host machine or any machine on the internet) as virtual serial console.

To enable the serial console, do the following at the command prompt:

```
$ unisim-virtex5fxt-wfpu-1.0beta11 \  
-s enable-telnet=true \  
-s telnet.telnet-tcp-port=1234
```

During initialization, the simulator waits for a telnet client connection on the telnet port. In another console, connect a telnet client to the simulator:

```
$ telnet localhost 1234
```

At this point, the user can interact with the target application using the telnet client.

4.4 Using the builtin debugger

The simulator has an integrated debugger for debugging the target application in a non-intrusive manner.

To enable the inline-debugger, do the following at the command prompt:

```
$ unisim-virtex5fxt-wfpu-1.0beta11 -s enable-inline-debugger=true
```

The user can enter classical debug commands from the debugger, such as putting breakpoints, watchpoints, stepping instructions, disassembling, dumping memory regions, etc.

To obtain help within the debugger, use the debugger command `help`:

```
inline-debugger> help
```

4.5 Using a GNU crosstool chain

4.5.1 Building a GNU crosstool chain

A crosstool chain is a tool chain to create and manipulate binary programs for a target architecture and operating system (e.g. PowerPC/Linux) that are different from host architecture and operating system (e.g. x86/Linux) that runs the tool chain. Building a GNU crosstool chain from scratch is a very tedious task. The process consists of a quite high number of undocumented steps, and mostly relies on the users experience. Fortunately a community sharing its experience, the `crossgcc` mailing list, actively supports a tool, `crosstool-NG`, that considerably simplifies the process of building a crosstool chain. Xilinx Virtex-5 FXT embedded processor is a PPC440x5 and Xilinx Platform Studio provides a PowerPC hardware FPU. Hence, from now, we will focus our effort on creating a crosstool chain with GNU GCC 4.7.2 (`gcc` and `g++`), GNU C library 2.16.0 (`glibc`), GNU binutils 2.22 (`ld`, `objdump`, and `readelf`), and GNU GDB 7.4.1 (`gdb`) for target `powerpc-440fp-linux-gnu`.

1. Get crosstool-NG: Download the crosstool-NG archive (e.g. `crosstool-ng-1.18.0.tar.bz2`) from this page: <http://crosstool-ng.org>
2. Uncompress crosstool-NG archive:

```
$ tar jxvf crosstool-ng-1.18.0.tar.bz2
```

3. Configure crosstool-NG build:

```
$ cd crosstool-ng-1.18.0
$ ./configure --enable-local
```

4. Compile crosstool-NG

```
$ make
```

5. Configure the crosstool chain build as shown on Figure 2:

```
$ ./ct-ng menuconfig
```

6. Build the crosstool chain (this may take tens of minutes/hours):

```
$ ./ct-ng build
```

7. You crosstool chain is ready in ``${HOME}`/crosstool/powerpc-440fp-linux-gnu`

```

Paths and misc options --->
(${HOME}/crosstool/powerpc-440fp-linux-gnu) Prefix directory

Target options --->
  Target Architecture (powerpc) --->
    (440fp) Emit assembly for CPU
    (440fp) Tune for CPU
    Floating point: (hardware (FPU)) --->

Toolchain options --->
  (440fp) Tuple's vendor string

Operating System --->
  Target OS (linux) --->
  Linux kernel version (3.7.3) --->

Binary utilities --->
  binutils version (2.22) --->

C compiler --->
  gcc version (4.7.2) --->
  [*] C++
  [ ] Link libstdc++ statically into the gcc binary

C-library --->
  C library (glibc) --->
  glibc version (2.16.0) --->
  (-g) gcc extra flags
  Minimum supported kernel version (Specific kernel version) --->
  Specific kernel version
  (2.6.9) Minimum kernel version to supports

Debug facilities --->
  [*] gdb --->

```

Figure 2: crosstool chain build configuration (changes from default only) for Crosstool-NG 1.18.0.

4.5.2 Using cross-GCC

A GCC cross-compiler together with a LD cross-linker can be used to create binaries for the target machine from the host machine:

```
$ ${HOME}/crosstool/powerpc-440fp-linux-gnu/bin/powerpc-440fp-linux-gnu-gcc \
    nodefaultlibs -nostdlib -mcpu=440fp -c hello.c -o hello.o
$ ${HOME}/crosstool/powerpc-440fp-linux-gnu/bin/powerpc-440fp-linux-gnu-ld hello.lds -o hello.elf
```

Simulator can directly loads such binary files, see Section 4.2.

4.5.3 Using cross-GDB

GNU GDB client can debug applications running on a remote/local host on the network. The application is run under the control of program `gdbserver` while program `gdb` only manages interactions with the user. Program `gdbserver` and `gdb` communicates over the TCP/IP network using a documented serial remote protocol. The simulator has a GDB server service that implements the GDB serial remote protocol, so that the simulator can acts as Program `gdbserver` from the GDB client point of view.

To enable the simulator GDB server, do the following at the command prompt:

```
$ unisim-virtex5fxt-wfpu-1.0beta11 -s enable-gdb-server=true -s gdb-server.tcp-port=1234
```

During initialization, the simulator waits for a GDB client connection on the GDB server TCP/IP port. In another console, connect a GDB client to the simulator:

```
$ powerpc-440fp-linux-gnu-gdb boot.elf
(gdb) target remote :1234
```

5 Examples of use

In this section, we present some examples of use for the simulator. We provide you with scripts and makefiles to build in an automatic manner all the examples. These examples are available for download in source and binary forms on our web site (<http://unisim-vp.org>):

- Basic system level unit tests: [[hyperlink to binaries](#)], [[hyperlink to sources](#)]
- MiBench version 1: [[hyperlink to binaries](#)], [[hyperlink to sources](#)]
- light weight Linux distribution: [[hyperlink to binaries](#)], [[hyperlink to sources](#)]

To build the examples you need a functional cross tool-chain for Target `powerpc-440fp-linux-gnu`, see Section 4.5.1. In later sub-sections, we assume that your cross tool-chain is installed in `${HOME}/crosstool/powerpc-440fp-linux-gnu`

5.1 Basic system level tests

Table 2 shows a summary of basic system level tests.

5.1.1 Description

Echo. The test reads characters from the serial console. It prints the read characters on the serial console.

Poll. The test polls the timer/counter #0. It prints some of the sampled values on the serial console.

Gen. The test uses the timer generate mode with interrupt generation every 100 μ s. It prints the tick of timer on the serial console.

Test Name	Directory	IntC	Timer	UART Lite	NOR Flash
Echo	xps_uart_lite/echo	✓		✓	
Poll	xps_timer/poll		✓	✓	
Gen	xps_timer/gen	✓	✓	✓	
Cap	xps_timer/cap	✓	✓	✓	
PWM	xps_timer/pwm	✓	✓	✓	
Autoselect	s29gl256p/autoselect	✓		✓	✓
CFI query	s29gl256p/cfi_query	✓		✓	✓
Chip erase	s29gl256p/chip_erase	✓		✓	✓
Sector erase	s29gl256p/sector_erase	✓		✓	✓
Single word programming	s29gl256p/single_word_programming	✓		✓	✓
Unlock bypass chip erase	s29gl256p/unlock_bypass_chip_erase	✓		✓	✓
Unlock bypass sector erase	s29gl256p/unlock_bypass_sector_erase	✓		✓	✓
Unlock bypass word programming	s29gl256p/unlock_bypass_word_programming	✓		✓	✓
Write buffer programming	s29gl256p/write_buffer_programming	✓		✓	✓

Table 2: Summary of basic system level tests.

Cap. The test uses the timer capture mode (randomized input between 1 μ s and 3.995 μ s). It prints the captured time stamp on the serial console.

PWM. The test uses the timer in PWM (Pulse Width Modulation) mode with a period of 2 μ s and a duty cycle of 300 ns.

Autoselect. The test puts the S29GL256P NOR Flash chip in autoselect mode. It reads the manufacturer and device IDs. It prints the two IDs on the serial console. It prints also protection status of each sector.

CFI query. The test puts the S29GL256P NOR Flash chip in CFI (Common Flash Interface) query mode. It queries the unique ASCII string "QRY". For each of the three characters, it prints on the serial console whether they match what is expected ("QRY").

Chip erase. The test erases the S29GL256P NOR Flash chip. It checks that all sectors have been erased.

Sector erase. The test erases the S29GL256P NOR Flash chip, one sector at a time. It checks that all sectors have been erased.

Single word programming. The test program a word on the S29GL256P NOR Flash chip. It verifies that word has been effectively programmed.

Unlock bypass chip erase. The test erases the S29GL256P NOR Flash chip four times. It checks that all sectors have been erased.

Unlock bypass sector erase. The test erases the S29GL256P NOR Flash chip, one sector at a time. It checks that all sectors have been erased.

Unlock bypass word programming. The test programs four words in the S29GL256P NOR Flash chip, one word at a time. It verifies that the four words have been effectively programmed.

Write buffer programming. The test programs four words in the S29GL256P NOR Flash chip, using the write buffer. It verifies that the four words have been effectively programmed.

5.1.2 Building the tests

From the directory where you uncompressed the archive, do the following at the command prompt:

```
$ make CROSS_COMPILE=${HOME}/crosstool/powerpc-440fp-linux-gnu/bin/powerpc-440fp-linux-gnu-
```

5.1.3 Running the tests

To check in an automatic manner that the UNISIM Virtex 5 FXT simulator correctly runs the system level unit tests, do the following at the command prompt:

```
$ ./check.sh ${HOME}/unisim-virtex5fxt-1.0beta11/virtex5fxt/bin/unisim-virtex5fxt-wfpu-1.0beta11
```

You should get the following output:

```
Running xps_timer/poll...done
Running xps_timer/pwm...done
Running xps_timer/gen...done
Running xps_timer/cap...done
Running s29gl256p/single_word_programming...done
Running s29gl256p/unlock_bypass_word_programming...done
Running s29gl256p/cfi_query...done
Running s29gl256p/sector_erase...done
Running s29gl256p/chip_erase...done
Running s29gl256p/autoselect...done
Running s29gl256p/unlock_bypass_sector_erase...done
Running s29gl256p/write_buffer_programming...done
Running s29gl256p/unlock_bypass_chip_erase...done
Running xps_uart_lite/echo...done
xps_timer/poll:PASS
xps_timer/pwm:PASS
xps_timer/gen:PASS
xps_timer/cap:PASS
s29gl256p/single_word_programming:PASS
s29gl256p/unlock_bypass_word_programming:PASS
s29gl256p/cfi_query:PASS
s29gl256p/sector_erase:PASS
s29gl256p/chip_erase:PASS
s29gl256p/autoselect:PASS
s29gl256p/unlock_bypass_sector_erase:PASS
s29gl256p/write_buffer_programming:PASS
s29gl256p/unlock_bypass_chip_erase:PASS
xps_uart_lite/echo:PASS
```

5.2 The MiBench version 1 benchmarks

5.2.1 Description

The MiBench [13, 1] version 1 is a free, commercially representative embedded benchmark suite. Most of the benchmarks come with small and large data sets. Table 3 summarizes the available benchmarks and their current status. Be aware that some of the benchmarks are so difficult to cross-compile (they were only intended to be natively compiled on the machine that will run them) that we gave up to build them. Also note that some benchmarks do not run correctly on PowerPC processors because these benchmarks wrongly assume endianness (PowerPC processors' natural endianness is big-endian, whereas standard PC processors are little-endian). When such limitations exist, they are explained in the status column of the table.

5.2.2 Building the benchmarks

From the directory where you uncompressed the archive, do the following at the command prompt:

```
$ ./build.sh all powerpc-440fp-linux-gnu ${HOME}/crosstool/powerpc-440fp-linux-gnu
```

5.2.3 Running the benchmarks

The simulator can easily run the MiBench version 1 benchmarks for Linux/PPC440FP without booting Linux. To do so, the simulator implements a mechanism known as Linux system call translation, also known as User Mode simulation. It means that a set of Linux system calls are passed through the host operating system, so that it is possible for the loaded applications to access the host file system, read user inputs, and print messages on the console.

To execute the benchmarks in an automatic manner on a Linux/PPC440FP target machine, do the following at the command prompt:

```
$ ./auto.sh run powerpc-440fp-linux
```

To execute the benchmarks in an automatic manner on the UNISIM Virtex 5 FXT simulator, do the following at the command prompt:

```
$ ./auto.sh sim powerpc-440fp-linux \  
  ${HOME}/unisim-virtex5fxt-1.0beta11/virtex5fxt/bin/unisim-virtex5fxt-wfpu-1.0beta11
```

To check that the results from the PPC440FP target and the simulator match, do the following at the command prompt:

```
$ ./auto.sh check powerpc-440fp-linux ref powerpc-440fp-linux sim
```

You should get the following output:

```
automotive basicmath large:pass  
automotive basicmath small:pass  
automotive bitcount large:pass  
automotive bitcount small:pass  
automotive qsort large:pass  
automotive qsort small:pass  
automotive susan large:pass  
automotive susan small:pass  
consumer jpeg large:pass  
consumer jpeg small:pass  
consumer lame large:pass  
consumer lame small:pass  
consumer typeset large:pass  
consumer typeset small:pass
```

Benchmark	Category	Description	Status
sha	security	160-bit secure hash algorithm	OK
blowfish	security	Blowfish encryption and decryption	OK
rijndael	security	AES encryption and decryption	OK after patching <code>aesxam.c</code> (use <code>ftell</code> instead of <code>fgetpos</code>)
pgp	security	Asymmetric (public key) encryption and decryption	OK
qsort	automotive	Sorting algorithm	OK
susan	automotive	Corner and edge recognition	OK
basicmath	automotive	Solving cubic polynomial, computing integer square root and converting angles	OK
bitcount	automotive	Count set bits in integer	OK
dijkstra	network	Shortest path in a graph	OK
FFT	telecomm	Fast Fourier Transform	OK
GSM	telecomm	Global System for Mobile Communications encoder and decoder	OK
CRC32	telecomm	32-bit Cyclic Redundancy Check	OK
ADPCM	telecomm	Adaptative Differential Pulse Code Modulation encoder and decoder	OK
typeset	consumer	A batch document formatter	OK
lame	consumer	MP3 encoder	OK
mad	consumer	MPEG audio decoding	Can't get it to cross-compile
JPEG	consumer	JPEG encoder and decoder	OK
tiff	office	Conversion and Dithering of pictures	Can't get it to cross-compile
ghostscript	office	Postscript renderer	Crashes on PowerPC
ispell	office	Spell checker	Fail (input files are endian-sensitive)
stringsearch	office	Search for words in text	OK
rsynth	office	Text to speech synthesis	OK
sphinx	office	Speech decoder	Can't be compiled on modern compilers

Table 3: MiBench version 1.0.

```

network dijkstra large:pass
network dijkstra small:pass
network patricia large:pass
network patricia small:pass
office stringsearch large:pass
office stringsearch small:pass
security blowfish large:pass
security blowfish small:pass
security pgp:pass
security rijndael large:pass
security rijndael small:pass
security sha large:pass
security sha small:pass
telecomm adpcm large:pass
telecomm adpcm small:pass
telecomm CRC32 large:pass
telecomm CRC32 small:pass
telecomm FFT large:pass
telecomm FFT small:pass
telecomm gsm large:pass
telecomm gsm small:pass

```

5.3 A light weight Linux distribution

The simulator can easily run a minimalist Linux distribution for a Xilinx Virtex-5 FXT development board. Table 4 shows the files to load in the simulator to run such a minimalist Linux distribution. In later sub-sections, we explain how these files are obtained. We provides you with prebuilt files to allow you quickly boot a minimalist Linux distribution within the simulator. Go directly to Sub-section 5.3.7 if you don't bother about the technique behind creating a light weight Linux distribution for the simulator. To build such a minimalist Linux distribution, you need a working crosstool chain, see Section 4.5.1.

File	Start address	Memory	Description
boot.elf	0xffff0000	BRAM	Boot program
vmlinux	0x00000000	RAM	Linux kernel
device_tree.dtb	0x00800000	RAM	Device Tree
initrd.img	0x00900000	RAM	Initial RAM disk

Table 4: Files for booting Linux in the simulator.

5.3.1 The boot program

The boot program is loaded in BRAM which is behind the MPLB. At reset, the processor starts executing instructions from physical address `0xfffffff0`. Thus the boot program is located in memory so that it has an instruction (usually a branch) at that physical address. The role of the boot program is to initialize early boot and provides the Kernel with some parameters in the processor registers. Table 5 shows the registers that needs to be initialized before branching into the Linux Kernel entry point.

The boot program, which source is shown on Figure 3, has been designed to make instruction at Label `start` match the processor start address. Actually, a branch instructions to elsewhere in the boot program (Label `init`) is placed at the reset address. The boot program then starts enabling the MCI (Memory Controller Interface) so that processor can use RAM which is behind the MCI. It programs the MMU to map the whole 256 MB RAM in the processor address space. It initializes required register parameters of the Linux kernel, that is the device tree address into Register `r3`, the initial RAM disk address range into Registers `r4` and `r5`, the Linux kernel start

address into Register `SRR0`, and the value of MSR into Register `SRR1`. It then branches to the Linux kernel using an `rfi` instruction (return from interrupt).

5.3.2 The Linux kernel

The Linux kernel (aka. `vmlinux`) must be configured and built for the target platform. The steps to follow are:

1. Get the Linux kernel source code: Download the `linux-3.0.4.tar.bz2` tarball at `ftp://ftp.kernel.org/pub/linux/kernel/v3.x/linux-3.0.4.tar.bz2`.

2. Uncompress the tarball

```
$ tar jxvf linux-3.0.4.tar.bz2
```

3. Before starting configuring the Linux kernel build, we need to modify a Linux configuration file to enable support of hardware FPU. In File `arch/powerpc/platforms/44x/Kconfig`, after:

```
config XILINX_VIRTEX_5_FXT
    bool
    select XILINX_VIRTEX
```

add the following line:

```
select PPC_FPU
```

4. We can now configure the Linux kernel build:

```
$ make \
  ARCH=powerpc \
  CROSS_COMPILE=${HOME}/crosstool/powerpc-440fp-linux-gnu/bin/powerpc-440fp-linux-gnu- \
  V=1 menuconfig
```

The Linux kernel should be configured as shown on Figure 4. Once configuration is finished, at exit don't forget to answer "Yes" when prompted for saving the settings in File `.config`.

5. The Linux kernel (`vmlinux`) can now be built. The build may take tens of minutes. Do the following at the command prompt:

```
$ make \
  ARCH=powerpc \
  CROSS_COMPILE=${HOME}/crosstool/powerpc-440fp-linux-gnu/bin/powerpc-440fp-linux-gnu- \
  V=1 vmlinux
```

5.3.3 The device Tree

On PowerPC embedded platforms, the Linux kernel uses a hierarchical list of devices, namely a device tree where leaves are devices and non-leaf nodes are buses, bridges and interconnects. It is a rather detailed machine description to allow the Linux kernel to correctly initialize devices and route interrupts to the interrupt routines. The boot loader or anything else launching the Linux kernel should provide the Linux kernel with the device tree. Linux provides a device tree compiler that compile a text description (`.dts` file) in a loadable binary form (`.dtb` file). Our example provides user with several device trees, that is one for each initial RAM disk size (6 MB, 8 MB, 12 MB, 16 MB, 24 MB, 32 MB, 64 MB and 96 MB). The provided device trees are:

Registers	Description
r3	Address of the device tree
r4	Start address of the initial RAM disk
r5	End address of the initial RAM disk

Table 5: Linux kernel register parameters.

```

1 #include "ppc44x_regs.h"
2 #define KERNEL_START 0x00000000
3 #define DEV_TREE_PTR 0x00800000
4 #define INITRD_START 0x00900000
5 #define INITRD_END 0x01900000
6 #define TLB0 0x00000250 /* map 0x00000000 (256 MB) in system address space */
7 #define TLB1 0x0 /* at physical address 0x0 */
8 #define TLB2 0x7 /* with access control SX=1 SW=1 SR=1 */
9
10 #define MI_CONTROL 0x10
11 #define MI_CONTROL_ENABLE 0x8000
12
13 .section ".text"
14 .org 0
15
16 init:
17 mfdcr r0, MI_CONTROL
18 oris r0, r0, MI_CONTROL_ENABLE
19 mtdcr MI_CONTROL, r0 /* enable MCI */
20 li r0, 0 /* TLB entry #0 */
21 lis r8, TLB0@h
22 ori r8, r8, TLB0@l
23 li r9, 0
24 mtspr MMUCR, r9 /* MMUCR[STID] = 0 */
25 lis r10, TLB1@h
26 ori r10, r10, TLB1@l
27 lis r11, TLB2@h
28 ori r11, r11, TLB2@l
29 tlbwe r8, r0, 0 /* Set EPN, V, TS, SIZE, TID of UTLB entry #0 word #0 */
30 tlbwe r10, r0, 1 /* Set RPN, ERPN of UTLB entry #0 word #1 */
31 tlbwe r11, r0, 2 /* Set U0 U1 U2 U3 W I M G E UX UW UR SX SW SR of UTLB entry #0 word #2 */
32 lis r3, DEV_TREE_PTR@h
33 ori r3, r3, DEV_TREE_PTR@l /* r3 <- device tree address */
34 lis r4, INITRD_START@h
35 ori r4, r4, INITRD_START@l /* r4 <- initrd start */
36 lis r5, INITRD_END@h
37 ori r5, r5, INITRD_END@l /* r5 <- initrd end */
38 li r6, 0 /* r6 <- start of kernel command line (unused as kernel command line is in dev tree) */
39 li r7, 0 /* r7 <- end of kernel command line (unused as kernel command line is in dev tree) */
40 lis r0, KERNEL_START@h
41 ori r0, r0, KERNEL_START@l
42 mtspr SRR0, r0 /* SRR0 <- kernel start address */
43 li r1, 0
44 mtspr SRR1, r1 /* MSR <- 0 */
45 rfi /* Branch to Linux kernel and invalidate shadow TLBs */
46
47 .global start
48 .org 0xffc
49 start:
50 b init

```

Figure 3: Boot program (boot.S compiled as boot.elf) loaded in BRAM.

```

Processor support --->
    Processor Types (AMCC 44x, 46x or 47x)

General Setup --->
    [*] Initial RAM filesystem and RAM disk (initramfs/initrd) support

Platform support --->
    [*] Generic Xilinx Virtex 5 FXT board support

Device Drivers --->
    [*] Block devices --->
        (16) Default number of RAM disks
        (65536) Default RAM disk size (kbytes)

        Character devices --->
            Serial drivers --->
                <*> Xilinx uartlite serial port support
                [*] Support for console on Xilinx uartlite serial port

    [*] GPIO Support --->
        [*] Xilinx GPIO support

    [*] Watchdog Timer Support --->
        <*> PowerPC Book-E Watchdog Timer

File systems --->
    <*> Second extended fs support

Kernel hacking --->
    [*] Compile the kernel with debug info

```

Figure 4: Linux kernel configuration (changes from default only).

1. `device-tree-6m.dtb`: device tree for a 6 MB large initial RAM disk
2. `device-tree-8m.dtb`: device tree for a 8 MB large initial RAM disk
3. `device-tree-16m.dtb`: device tree for a 16 MB large initial RAM disk
4. `device-tree-24m.dtb`: device tree for a 24 MB large initial RAM disk
5. `device-tree-16m.dtb`: device tree for a 16 MB large initial RAM disk
6. `device-tree-32m.dtb`: device tree for a 32 MB large initial RAM disk
7. `device-tree-64m.dtb`: device tree for a 64 MB large initial RAM disk
8. `device-tree-96m.dtb`: device tree for a 96 MB large initial RAM disk

5.3.4 The initial RAM disk

The initial RAM disk file is a file containing an image of the root file system. We consider creating an initial RAM disk with an Ext2 file system in it. Note that creating an image requires root privileges because mounting a file system requires root privileges.

The steps to follow are:

1. Create an empty image (`initrd.img`) of 16 MB:

```
[root@localhost] $ dd if=/dev/zero of=initrd.img count=16384 bs=1024
```

2. Create an Ext2 file system in image:

```
[root@localhost] $ mke2fs -F -m 0 initrd.img
```

3. Create a mount point and mount image on it:

```
[root@localhost] $ mkdir /media/initrd
[root@localhost] $ mount -o loop initrd.img /mnt/initrd
```

4. Now you can directly access withing the image using directory `/mnt/initrd`. In directory `/mnt/initrd`, copy every files and directories you want in your image.

5. Unmount image:

```
[root@localhost] $ umount /media/initrd
```

We provide several prebuilt initial RAM disks. Some of the initial RAM disks contain a MiBench benchmark (see Table 3) in `/opt`. Table 6 summarizes the prebuilt initial RAM disks.

Initial RAM disk	Content
initrd.img	Busybox only
initrd_automotive_basicmath_large.img	Busybox + automotive/basicmath (large data set)
initrd_automotive_basicmath_small.img	Busybox + automotive/basicmath (small data set)
initrd_automotive_bitcount_large.img	Busybox + automotive/bitcount (large data set)
initrd_automotive_bitcount_small.img	Busybox + automotive/bitcount (small data set)
initrd_automotive_qsort_large.img	Busybox + automotive/qsort (large data set)
initrd_automotive_qsort_small.img	Busybox + automotive/qsort (small data set)
initrd_automotive_susan_large.img	Busybox + automotive/susan (large data set)
initrd_automotive_susan_small.img	Busybox + automotive/susan (small data set)
initrd_consumer_jpeg_large.img	Busybox + consumer/JPEG MiBench (large data set)
initrd_consumer_jpeg_small.img	Busybox + consumer/JPEG MiBench (small data set)
initrd_consumer_lame_large.img	Busybox + consumer/lame (large data set)
initrd_consumer_lame_small.img	Busybox + consumer/lame (small data set)
initrd_consumer_typeset_large.img	Busybox + consumer/typeset (large data set)
initrd_consumer_typeset_small.img	Busybox + consumer/typeset (small data set)
initrd_network_dijkstra_large.img	Busybox + network/dijkstra (large data set)
initrd_network_dijkstra_small.img	Busybox + network/dijkstra (small data set)
initrd_network_patricia_large.img	Busybox + network/patricia (large data set)
initrd_network_patricia_small.img	Busybox + network/patricia (small data set)
initrd_office_ghostscript_large.img	Busybox + office/ghostscript (large data set)
initrd_office_ghostscript_small.img	Busybox + office/ghostscript (small data set)
initrd_office_ispell_large.img	Busybox + office/ispell (large data set)
initrd_office_ispell_small.img	Busybox + office/ispell (small data set)
initrd_office_rsynth_large.img	Busybox + office/rsynth (large data set)
initrd_office_rsynth_small.img	Busybox + office/rsynth (small data set)
initrd_office_stringsearch_large.img	Busybox + office/stringsearch (large data set)
initrd_office_stringsearch_small.img	Busybox + office/stringsearch (small data set)
initrd_security_blowfish_large.img	Busybox + security/blowfish (large data set)
initrd_security_blowfish_small.img	Busybox + security/blowfish (small data set)
initrd_security_pgp.img	Busybox + security/PGP
initrd_security_rijndael_large.img	Busybox + security/rijndael (large data set)
initrd_security_rijndael_small.img	Busybox + security/rijndael (small data set)
initrd_security_sha_large.img	Busybox + security/sha (large data set)
initrd_security_sha_small.img	Busybox + security/sha (small data set)
initrd_telecomm_adpcm_large.img	Busybox + telecomm/ADPCM (large data set)
initrd_telecomm_adpcm_small.img	Busybox + telecomm/ADPCM (small data set)
initrd_telecomm_crc32_large.img	Busybox + telecomm/CRC32 (large data set)
initrd_telecomm_crc32_small.img	Busybox + telecomm/CRC32 (small data set)
initrd_telecomm_fft_large.img	Busybox + telecomm/FFT (large data set)
initrd_telecomm_fft_small.img	Busybox + telecomm/FFT (small data set)
initrd_telecomm_gsm_large.img	Busybox + telecomm/GSM (large data set)
initrd_telecomm_gsm_small.img	Busybox + telecomm/GSM (small data set)

Table 6: Initial RAM disks.

5.3.5 Busybox

Busybox is a light weight shell that includes most of standard UNIX commands. Actually commands are symbolic links to the busybox binary. Busybox knows which commands to implement looking at its `argv[0]`. It is usually a good idea to install Busybox in the initial RAM disk image of an Linux-based embedded platform because it's tiny and easy to cross-compile. The Linux kernel (`vmlinux`), at the end of the boot procedure, starts `linuxrc` located at the root of the root file system (e.g. in an initial RAM disk on device `/dev/ram0`). Usually `linuxrc` is a symbolic link to the boot shell (e.g. the Busybox ash shell located at `/bin/ash`).

5.3.6 Building the distribution

From the directory where you uncompressed the archive, do the following at the command prompt:

```
$ ./build.sh all ${HOME}/mibench-v1-source-v3/builds/powerpc-440fp-linux-gnu \  
    ${HOME}/crosstool/powerpc-440fp-linux-gnu
```

5.3.7 Booting the distribution

A very small Linux distribution based on Busybox together with a configuration file are provided for the simulator. To boot that small Linux distribution within the simulator, do the following at the command prompt:

```
$ cd linux_distro  
$ unisim-virtex5fxt-wfpu-1.0beta11 -c config/sim_config.xml
```

The simulator acts as a telnet server to emulate a terminal over the XPS UART Lite. Once started, it waits for a telnet client connection like `telnet` or `PuTTY`. To connect the telnet client to the simulator, do the following at the command prompt:

```
$ telnet localhost 1234
```

You can see (in the telnet terminal) the Linux distribution booting in the simulator:

```
[ 0.000000] Using Xilinx Virtex440 machine description  
[ 0.000000] Linux version 3.0.4 (unisim-vp@unisim-vp.org) (gcc version  
4.4.6 (crosstool-NG 1.13.2) ) #2 PREEMPT Thu Jan 1 00:00:00 CEST 1970  
[ 0.000000] Found initrd at 0xc0900000:0xc1900000  
[ 0.000000] Zone PFN ranges:  
[ 0.000000]   DMA      0x00000000 -> 0x00001000  
[ 0.000000]   Normal  empty  
[ 0.000000] Movable zone start PFN for each node  
[ 0.000000] early_node_map[1] active PFN ranges  
[ 0.000000]     0: 0x00000000 -> 0x00001000  
[ 0.000000] MMU: Allocated 1088 bytes of context maps for 255 contexts  
[ 0.000000] Built 1 zonelists in Zone order, mobility grouping off. Total pages: 4094  
[ 0.000000] Kernel command line: root=/dev/ram0 rw init=linuxrc console=ttyUL0  
[ 0.000000] PID hash table entries: 1024 (order: -4, 4096 bytes)  
[ 0.000000] Dentry cache hash table entries: 32768 (order: 1, 131072 bytes)  
[ 0.000000] Inode-cache hash table entries: 16384 (order: 0, 65536 bytes)  
[ 0.000000] Memory: 240128k/262144k available (3776k kernel code, 22016k reserved,  
448k data, 620k bss, 256k init)  
[ 0.000000] Kernel virtual memory layout:  
[ 0.000000] * 0xffffd0000..0xffff0000 : fixmap  
[ 0.000000] * 0xfde00000..0xfe000000 : consistent mem  
[ 0.000000] * 0xfde00000..0xfde00000 : early ioremap  
[ 0.000000] * 0xd1000000..0xfde00000 : vmalloc & ioremap  
[ 0.000000] Preemptible hierarchical RCU implementation.  
[ 0.000000] NR_IRQS:512
```

```

[ 0.000000] clocksource: timebase mult[a00000] shift[22] registered
[ 0.000000] Console: colour dummy device 80x25
[ 0.000343] pid_max: default: 32768 minimum: 301
[ 0.000802] Mount-cache hash table entries: 8192
[ 0.007581] NET: Registered protocol family 16
[ 0.009045] PCI: Probing PCI hardware
[ 0.018693] bio: create slab <bio-0> at 0
[ 0.019190] XGpio: /plb0/gpio@81460000: registered
[ 0.019403] XGpio: /plb0/gpio@81400000: registered
[ 0.019618] XGpio: /plb0/gpio@81420000: registered
[ 0.019831] XGpio: /plb0/gpio@81440000: registered
[ 0.020361] vgaarb: loaded
[ 0.021282] Switching to clocksource timebase
[ 0.037828] NET: Registered protocol family 2
[ 0.038118] IP route cache hash table entries: 16384 (order: 0, 65536 bytes)
[ 0.039300] TCP established hash table entries: 8192 (order: 0, 65536 bytes)
[ 0.039638] TCP bind hash table entries: 8192 (order: -1, 32768 bytes)
[ 0.039836] TCP: Hash tables configured (established 8192 bind 8192)
[ 0.039851] TCP reno registered
[ 0.039869] UDP hash table entries: 4096 (order: 0, 65536 bytes)
[ 0.040208] UDP-Lite hash table entries: 4096 (order: 0, 65536 bytes)
[ 0.041188] NET: Registered protocol family 1
[ 0.041734] RPC: Registered named UNIX socket transport module.
[ 0.041751] RPC: Registered udp transport module.
[ 0.041764] RPC: Registered tcp transport module.
[ 0.041778] RPC: Registered tcp NFSv4.1 backchannel transport module.
[ 0.041965] Trying to unpack rootfs image as initramfs...
[ 0.042228] rootfs image is not initramfs (junk in compressed archive); looks like an initrd
[ 0.089044] Freeing initrd memory: 16384k freed
[ 0.094043] ROMFS MTD (C) 2007 Red Hat, Inc.
[ 0.094294] msgmni has been set to 500
[ 0.094696] io scheduler noop registered
[ 0.094709] io scheduler deadline registered
[ 0.094790] io scheduler cfq registered (default)
[ 0.273876] 84000000.serial: ttyUL0 at MMIO 0x84000000 (irq = 19) is a uartlite
[ 0.274651] console [ttyUL0] enabled
[ 0.282141] brd: module loaded
[ 0.286330] loop: module loaded
[ 0.286568] Error: Driver 'xsysace' is already registered, aborting...
[ 0.286741] xsysace: registration failed; err=-16
[ 0.288341] mousedev: PS/2 mouse device common for all mice
[ 0.288842] booke_wdt: powerpc book-e watchdog driver loaded
[ 0.290497] TCP cubic registered
[ 0.290521] NET: Registered protocol family 17
[ 0.292335] RAMDISK: ext2 filesystem found at block 0
[ 0.292374] RAMDISK: Loading 16384KiB [1 disk] into ram disk... done.
[ 0.632474] VFS: Mounted root (ext2 filesystem) on device 1:0.
[ 0.632744] Freeing unused kernel memory: 256k init
starting pid 747, tty '': '/etc/init.d/rcS'
starting pid 750, tty '': '/bin/cttyhack /etc/init.sh'

```

```

BusyBox v1.19.3 (2012-09-11 13:47:51 CEST) built-in shell (ash)
Enter 'help' for a list of built-in commands.

```

```
[/]$
```

Once the boot is over, you can enter shell commands at the command prompt in the telnet terminal. For example, you can ask for CPU informations to the Linux kernel by doing the following at the command prompt in the telnet terminal:

```

[/]$ cat /proc/cpuinfo
processor       : 0
cpu           : 440 in Virtex-5 FXT

```

```

clock           : 400.000000MHz
revision        : 25.18 (pvr 7ff2 1912)
bogomips       : 800.00
timebase       : 400000000
platform       : Xilinx Virtex440
model          : testing
Memory         : 256 MB
[/]$

```

You may also want to try some MiBench benchmarks within that small Linux distribution. We provide an initial RAM disk for almost each MiBench benchmark and the corresponding simulator configuration file. For example, to run the MiBench Lame benchmark (large data set), do the following at the command prompt:

```

$ cd linux_distro
$ unisim-virtex5fxt-wfpu-1.0beta11 -c config/sim_config_consumer_lame_large.xml

```

In another console, connect the telnet client to the simulator:

```

$ telnet localhost 1234

```

Note: The UNISIM Virtex 5 FXT Simulator must have the hardware FPU enabled (`unisim-virtex5fxt-wfpu-1.0beta11`) to run a Linux kernel for `powerpc-440fp-linux-gnu`. When the simulator has the hardware FPU disabled (`unisim-virtex5fxt-1.0beta11`, the simulator can only use the Linux kernel for `powerpc-440-linux-gnu`.

To check (this may take tens of minutes/hours) in an automatic mannner that the UNISIM Virtex 5 FXT simulator correctly boots Linux and runs the MiBench version 1 benchmarks, do the following at the command prompt:

```

$ ./check.sh ${HOME}/unisim-virtex5fxt-1.0beta11/virtex5fxt/bin/unisim-virtex5fxt-wfpu-1.0beta11 1234

```

Note: the Netcat utility (either traditional or BSD version) must be installed.

You should get the following output:

```

Launching automotive_basicmath_small (job #1 of 35)...ok
Launching automotive_basicmath_large (job #2 of 35)...ok
Launching automotive_bitcount_small (job #3 of 35)...ok
Launching automotive_bitcount_large (job #4 of 35)...ok
Launching automotive_qsort_small (job #5 of 35)...ok
Launching automotive_qsort_large (job #6 of 35)...ok
Launching automotive_susan_small (job #7 of 35)...ok
Launching automotive_susan_large (job #8 of 35)...ok
Launching consumer_jpeg_small (job #9 of 35)...ok
Launching consumer_jpeg_large (job #10 of 35)...ok
Launching consumer_lame_small (job #11 of 35)...ok
Launching consumer_lame_large (job #12 of 35)...ok
Launching consumer_typeset_small (job #13 of 35)...ok
Launching consumer_typeset_large (job #14 of 35)...ok
Launching network_dijkstra_small (job #15 of 35)...ok
Launching network_dijkstra_large (job #16 of 35)...ok
Launching network_patricia_small (job #17 of 35)...ok
Launching network_patricia_large (job #18 of 35)...ok
Launching office_stringsearch_small (job #19 of 35)...ok
Launching office_stringsearch_large (job #20 of 35)...ok
Launching security_blowfish_small (job #21 of 35)...ok
Launching security_blowfish_large (job #22 of 35)...ok
Launching security_pgp (job #23 of 35)...ok
Launching security_rijndael_small (job #24 of 35)...ok
Launching security_rijndael_large (job #25 of 35)...ok
Launching security_sha_small (job #26 of 35)...ok
Launching security_sha_large (job #27 of 35)...ok

```

Launching telecomm_adpcm_small (job #28 of 35)...ok
Launching telecomm_adpcm_large (job #29 of 35)....ok
Launching telecomm_crc32_small (job #30 of 35)...ok
Launching telecomm_crc32_large (job #31 of 35)....ok
Launching telecomm_fft_small (job #32 of 35)...ok
Launching telecomm_fft_large (job #33 of 35)....ok
Launching telecomm_gsm_small (job #34 of 35)...ok
Launching telecomm_gsm_large (job #35 of 35)....ok
automotive_basicmath_small:PASS
automotive_basicmath_large:PASS
automotive_bitcount_small:PASS
automotive_bitcount_large:PASS
automotive_qsort_small:PASS
automotive_qsort_large:PASS
automotive_susan_small:PASS
automotive_susan_large:PASS
consumer_jpeg_small:PASS
consumer_jpeg_large:PASS
consumer_lame_small:PASS
consumer_lame_large:PASS
consumer_typeset_small:PASS
consumer_typeset_large:PASS
network_dijkstra_small:PASS
network_dijkstra_large:PASS
network_patricia_small:PASS
network_patricia_large:PASS
office_stringsearch_small:PASS
office_stringsearch_large:PASS
security_blowfish_small:PASS
security_blowfish_large:PASS
security_pgp:PASS
security_rijndael_small:PASS
security_rijndael_large:PASS
security_sha_small:PASS
security_sha_large:PASS
telecomm_adpcm_small:PASS
telecomm_adpcm_large:PASS
telecomm_crc32_small:PASS
telecomm_crc32_large:PASS
telecomm_fft_small:PASS
telecomm_fft_large:PASS
telecomm_gsm_small:PASS
telecomm_gsm_large:PASS

Appendices

A Simulator technical reference (generated)

This documentation has been automatically generated from the simulator UNISIM Virtex 5 FXT version 1.0beta12 on Dec 12 2014.

A.1 Introduction

UNISIM Virtex 5 FXT, full system PPC440x5 based simulator including some Virtex 5 IPs. Section A.2 gives licensing informations about the simulator. Section A.3 shows the set of modules and services that compose the simulator. Section A.4 shows how to invoke the simulator at the command line prompt. Section A.5 gives the simulator parameters. Section A.6 gives the simulator statistic counters. Section A.7 gives the simulator statistic formulas.

A.2 Licensing

UNISIM Virtex 5 FXT 1.0beta12

Copyright (C) 2007-2011, Commissariat a l'Energie Atomique (CEA)

License: BSD (see file COPYING)

Authors: Gilles Mouchard <gilles.mouchard@cea.fr>, Daniel Gracia Pérez <daniel.gracia-perez@cea.fr>

A.3 Simulated configuration

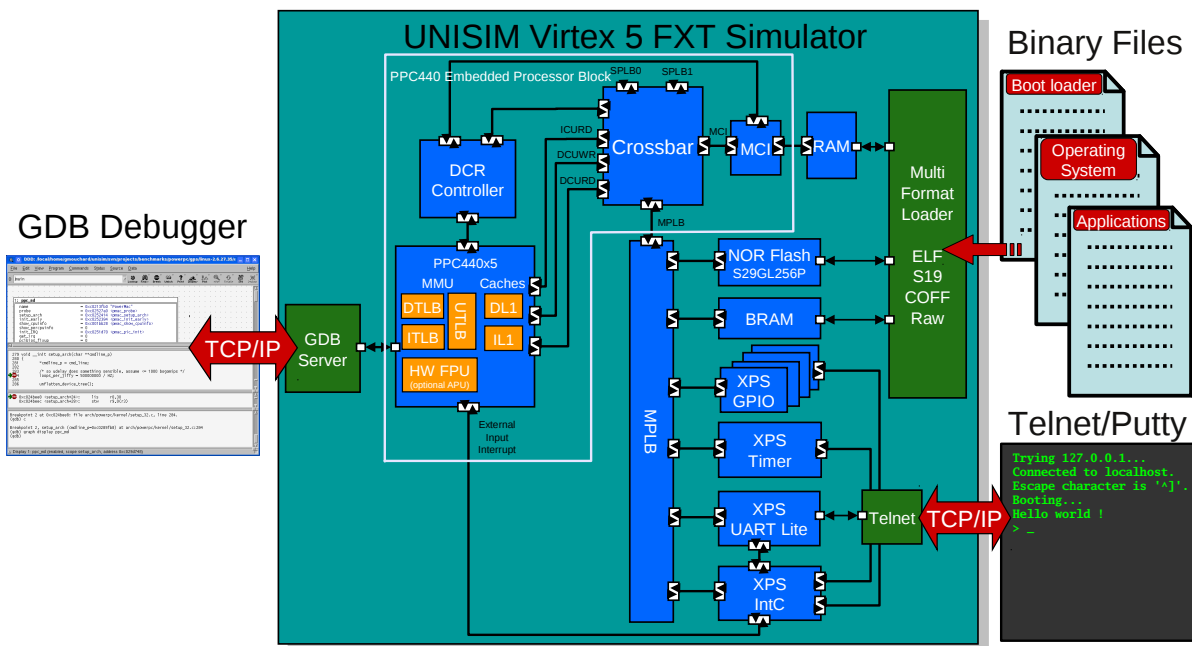

Figure 5: UNISIM Virtex 5 FXT simulator schematic.

The UNISIM Virtex 5 FXT simulator is composed of the following modules and services:

- **5-leds-positions**: This module implements a 5-LED board on GPIO.
- **apu-dcr-stub**: A target stub

- **bram**: this module implements a memory
- **bram-effective-to-physical-address-translator**: this service translates memory addresses when playing with different address sizes
- **capture-trigger-stub0**: A stub that, if enabled, can generate random inputs for a capture timer
- **capture-trigger-stub1**: A stub that, if enabled, can generate random inputs for a capture timer
- **cpu**: This module implements a PPC440 CPU core. It has the following characteristics:
 Processor version (PVR value): 0x7ff21912
 Reset configuration (RSTCFG): U0=0, U1=0, U2=0, U3=0, E=0, ERPN=0x0
 Start address: 0xffffffc
 L1 data cache: size=32768 bytes, block size=32 bytes, associativity=64
 L1 instruction cache: size=32768 bytes, block size=32 bytes, associativity=64
 shadow instruction TLB: size=4 entries, associativity=4
 shadow data TLB: size=8 entries, associativity=8
 unified TLB: size=64 entries, associativity=64
 FSB/PLB burst size:256 bits
 FSB/PLB width:128 bits
 MMU: yes
 FPU APU: no
- **critical-input-interrupt-stub**: An initiator stub
- **crossbar**: This module implements the crossbar of the embedded processor block in Virtex-5 FXT FPGAs from Xilinx. It has the following address mappings at reset:
 ICURD mapping:
 - 0x0-0x7ffffff → MCI
 - 0x80000000-0xffffffff → MPLB
 DCUWR mapping:
 - 0x0-0x7ffffff → MCI
 - 0x80000000-0xffffffff → MPLB
 DCURD mapping:
 - 0x0-0x7ffffff → MCI
 - 0x80000000-0xffffffff → MPLB
 SPLB0 mapping:
 - 0x0-0xffffffff → MCI
 SPLB1 mapping:
 - 0x0-0xffffffff → MCI
- **dcr-controller**: A Device Control Register bus controller
- **debugger**
- **dip-switches-8bit**: This module implements a 8-switch board (DIP switch or push buttons) on GPIO.
- **dma0-dcr-stub**: A target stub
- **dma1-dcr-stub**: A target stub
- **dma2-dcr-stub**: A target stub
- **dma3-dcr-stub**: A target stub
- **external-slave-dcr-stub**: A target stub

- **flash:** This module implements an S29GL256P flash memory with the following characteristics:
 - Manufacturer ID: 0x0001
 - Device ID word #0: 0x227e
 - Device ID word #1: 0x2222
 - Device ID word #2: 0x2201
 - Size: 33554432 bytes
 - I/O width: 16 bits
 - Number of chips: 1 chip
 - I/O width per chip: 16 bits
 - Size per chip: 33554432 bytes
 - Number of Sectors: 256 sectors
 - 8-bit mode support: yes
 - 16-bit mode support: yes
 - Access time: 100 ns
 - Byte programming time: 60000 us
 - Word programming time: 60000 us
 - Sector erasing time: 500000000 us
 - Chip erasing time: 128000000000 us
- **flash-effective-to-physical-address-translator:** this service translates memory addresses when playing with different address sizes
- **gdb-server:** this service implements the GDB server remote serial protocol over TCP/IP. Standards GDB clients (e.g. gdb, eclipse, ddd) can connect to the simulator to debug the target application that runs within the simulator.
- **generate-out-stub0:** A target stub
- **generate-out-stub1:** A target stub
- **gpio-5-leds-positions:** This module implements a Xilinx XPS GPIO (v2.00a). It has the following characteristics:
 - PLB data width: 128 bits
 - Use dual channel: no
 - GPIO Channel 1 width: 5 bits
 - GPIO_DATA reset value: 0x0
 - GPIO_TRI reset value: 0xffffffff
- **gpio-dip-switches-8bit:** This module implements a Xilinx XPS GPIO (v2.00a). It has the following characteristics:
 - PLB data width: 128 bits
 - Use dual channel: no
 - GPIO Channel 1 width: 8 bits
 - GPIO_DATA reset value: 0x0
 - GPIO_TRI reset value: 0xffffffff
- **gpio-leds-8bit:** This module implements a Xilinx XPS GPIO (v2.00a). It has the following characteristics:
 - PLB data width: 128 bits
 - Use dual channel: no
 - GPIO Channel 1 width: 8 bits
 - GPIO_DATA reset value: 0x0
 - GPIO_TRI reset value: 0xffffffff

- **gpio-push-buttons-5bit**: This module implements a Xilinx XPS GPIO (v2.00a). It has the following characteristics:
 - PLB data width: 128 bits
 - Use dual channel: no
 - GPIO Channel 1 width: 5 bits
 - GPIO_DATA reset value: 0x0
 - GPIO_TRI reset value: 0xffffffff

- **host-time**: this service is an abstraction layer for the host machine time
- **inline-debugger**: this service implements a built-in debugger in the terminal console
- **input-interrupt-stub0**: An initiator stub
- **input-interrupt-stub1**: An initiator stub
- **input-interrupt-stub10**: An initiator stub
- **input-interrupt-stub11**: An initiator stub
- **input-interrupt-stub12**: An initiator stub
- **input-interrupt-stub13**: An initiator stub
- **input-interrupt-stub14**: An initiator stub
- **input-interrupt-stub15**: An initiator stub
- **input-interrupt-stub16**: An initiator stub
- **input-interrupt-stub17**: An initiator stub
- **input-interrupt-stub18**: An initiator stub
- **input-interrupt-stub19**: An initiator stub
- **input-interrupt-stub20**: An initiator stub
- **input-interrupt-stub21**: An initiator stub
- **input-interrupt-stub22**: An initiator stub
- **input-interrupt-stub23**: An initiator stub
- **input-interrupt-stub24**: An initiator stub
- **input-interrupt-stub25**: An initiator stub
- **input-interrupt-stub26**: An initiator stub
- **input-interrupt-stub27**: An initiator stub
- **input-interrupt-stub28**: An initiator stub
- **input-interrupt-stub29**: An initiator stub
- **input-interrupt-stub30**: An initiator stub
- **input-interrupt-stub31**: An initiator stub
- **input-interrupt-stub4**: An initiator stub
- **input-interrupt-stub5**: An initiator stub
- **input-interrupt-stub6**: An initiator stub
- **input-interrupt-stub9**: An initiator stub

- **intc**: This module implements a Xilinx XPS Interrupt Controller (v2.01a). It has the following characteristics:
 - PLB data width: 128 bits
 - Number of interrupt inputs: 32 interrupt inputs
 - IPR support: yes
 - SIE support: yes
 - CIE support: yes
 - IVR support: yes
 - Ouput: active on high level
 - input #0 capture mode: rising edge
 - input #1 capture mode: rising edge
 - input #2 capture mode: rising edge
 - input #3 capture mode: rising edge
 - input #4 capture mode: rising edge
 - input #5 capture mode: rising edge
 - input #6 capture mode: rising edge
 - input #7 capture mode: rising edge
 - input #8 capture mode: rising edge
 - input #9 capture mode: rising edge
 - input #10 capture mode: rising edge
 - input #11 capture mode: rising edge
 - input #12 capture mode: rising edge
 - input #13 capture mode: rising edge
 - input #14 capture mode: rising edge
 - input #15 capture mode: rising edge
 - input #16 capture mode: rising edge
 - input #17 capture mode: rising edge
 - input #18 capture mode: rising edge
 - input #19 capture mode: rising edge
 - input #20 capture mode: rising edge
 - input #21 capture mode: rising edge
 - input #22 capture mode: rising edge
 - input #23 capture mode: rising edge
 - input #24 capture mode: rising edge
 - input #25 capture mode: rising edge
 - input #26 capture mode: rising edge
 - input #27 capture mode: rising edge
 - input #28 capture mode: rising edge
 - input #29 capture mode: rising edge
 - input #30 capture mode: rising edge
 - input #31 capture mode: rising edge
- **leds-8bit**: This module implements a 8-LED board on GPIO.
- **loader**: A multi-format loader that supports ELF32, ELF64, S19, COFF and Raw binary files
- **loader.memory-mapper**: A memory mapper
- **loader.tee-backtrace**: This service/client implements a tee ('T'). It unifies the backtrace capability of several services that individually provides their own backtrace capability
- **loader.tee-blob**: This service/client implements a tee ('T'). It unifies the statement lookup capability of several services that individually provides their own statement lookup

capability

- **loader.tee-loader**: This service/client implements a tee ('T'). It unifies the loader capability of several services that individually provides their own loader capability
- **loader.tee-stmt-lookup**: This service/client implements a tee ('T'). It unifies the statement lookup capability of several services that individually provides their own statement lookup capability
- **loader.tee-symbol-table-lookup**: This service/client implements a tee ('T'). It unifies the symbol table lookup capability of several services that individually provides their own symbol table lookup capability
- **master1-dcr-stub**: An initiator stub
- **mci**: A Memory Controller Interface (MCI)
- **mplb**: A memory-mapped router
- **profiler**
- **push-buttons-5bit**: This module implements a 5-switch board (DIP switch or push buttons) on GPIO.

- **pwm-stub**: A target stub
- **ram**: this module implements a memory
- **ram-effective-to-physical-address-translator**: this service translates memory addresses when playing with different address sizes
- **splb0-stub**: An initiator stub
- **splb1-stub**: An initiator stub
- **tee-memory-access-reporting**
- **tee-memory-access-reporting.tee-memory-access-reporting.control_selector[0]**
- **tee-memory-access-reporting.tee-memory-access-reporting.control_selector[10]**
- **tee-memory-access-reporting.tee-memory-access-reporting.control_selector[11]**
- **tee-memory-access-reporting.tee-memory-access-reporting.control_selector[12]**
- **tee-memory-access-reporting.tee-memory-access-reporting.control_selector[13]**
- **tee-memory-access-reporting.tee-memory-access-reporting.control_selector[14]**
- **tee-memory-access-reporting.tee-memory-access-reporting.control_selector[15]**
- **tee-memory-access-reporting.tee-memory-access-reporting.control_selector[1]**
- **tee-memory-access-reporting.tee-memory-access-reporting.control_selector[2]**
- **tee-memory-access-reporting.tee-memory-access-reporting.control_selector[3]**
- **tee-memory-access-reporting.tee-memory-access-reporting.control_selector[4]**
- **tee-memory-access-reporting.tee-memory-access-reporting.control_selector[5]**
- **tee-memory-access-reporting.tee-memory-access-reporting.control_selector[6]**
- **tee-memory-access-reporting.tee-memory-access-reporting.control_selector[7]**
- **tee-memory-access-reporting.tee-memory-access-reporting.control_selector[8]**
- **tee-memory-access-reporting.tee-memory-access-reporting.control_selector[9]**
- **time**: this service is an abstraction layer for the SystemC kernel time

- **timer**: This module implements a Xilinx XPS Timer/Counter (v1.02a). It has the following characteristics:
 PLB data width: 128 bits
 Width of the counters: 32 bits
 One timer only: no
 CaptureTrig0 assertion level: high
 CaptureTrig1 assertion level: high
 GenerateOut0 assertion level: high
 GenerateOut0 assertion level: high
- **uart-lite**: This module implements a Xilinx XPS UART Lite (v1.01a). It has the following characteristics:
 PLB data width: 128 bits
 Baud rate: 9600 bits/s
 Data bits: 8 bits
 Parity: odd

A.4 Using the UNISIM Virtex 5 FXT simulator

The UNISIM Virtex 5 FXT simulator has the following command line options:

Usage: `unisim-virtex5fxt-1.0beta12` [<options>] [...]

Options:

- `--set <param=value>` or `-s <param=value>`: set value of parameter 'param' to 'value'
- `--config <XML file>` or `-c <XML file>`: configures the simulator with the given XML configuration file
- `--get-config <XML file>` or `-g <XML file>`: get the simulator configuration XML file (you can use it to create your own configuration. This option can be combined with `-c` to get a new configuration file with existing variables from another file)
- `--list` or `-l`: lists all available parameters, their type, and their current value
- `--warn` or `-w`: enable printing of kernel warnings
- `--doc <Latex file>` or `-d <Latex file>`: enable printing a latex documentation
- `--version` or `-v`: displays the program version information
- `--share-path <path>` or `-p <path>`: the path that should be used for the share directory (absolute path)
- `--help` or `-h`: displays this help

A.5 Configuration

Simulator configuration (see below) can be modified using command line Options `--set <param=value>` or `--config <config file>`.

Global	
Name: <code>enable-gdb-server</code>	Type: parameter
Default: <code>true</code>	Data type: boolean
Valid: <code>true, false</code>	

Description: Enable/Disable GDB server instantiation.	
Name: enable-inline-debugger	Type: parameter
Default: true	Data type: boolean
Valid: true, false	
Description: Enable/Disable inline debugger instantiation.	
Name: enable-linux-os	Type: parameter
Default: false	Data type: boolean
Valid: true, false	
Description: Enable/Disable target Linux ABI to host ABI translation.	
Name: enable-press-enter-at-exit	Type: parameter
Default: false	Data type: boolean
Valid: true, false	
Description: Enable/Disable pressing key enter at exit.	
Name: enable-telnet	Type: parameter
Default: false	Data type: boolean
Valid: true, false	
Description: Enable/Disable telnet instantiation.	
Name: estimate-power	Type: parameter
Default: false	Data type: boolean
Valid: true, false	
Description: Enable/Disable power estimators instantiation.	
Name: kernel_logger.file	Type: parameter
Default: false	Data type: boolean
Valid: true, false	
Description: Keep logger output in a file.	
Name: kernel_logger.filename	Type: parameter
Default: logger_output.txt	Data type: string
Description: Filename to keep logger output _(the option file must be activated).	
Name: kernel_logger.std_err	Type: parameter
Default: true	Data type: boolean
Valid: true, false	

Description: Show logger output through the standard error output.	
Name: kernel_logger.std_err_color	Type: parameter
Default: false	Data type: boolean
Valid: true, false	
Description: Colorize logger output through the standard error output _(only works if std_err is active).	
Name: kernel_logger.std_out	Type: parameter
Default: false	Data type: boolean
Valid: true, false	
Description: Show logger output through the standard output.	
Name: kernel_logger.std_out_color	Type: parameter
Default: false	Data type: boolean
Valid: true, false	
Description: Colorize logger output through the standard output _(only works if std_out is active).	
Name: kernel_logger.xml_file	Type: parameter
Default: false	Data type: boolean
Valid: true, false	
Description: Keep logger output in a file xml formatted.	
Name: kernel_logger.xml_file_gzipped	Type: parameter
Default: false	Data type: boolean
Valid: true, false	
Description: If the xml_file option is active, the output file will be compressed (a .gz extension will be automatically added to the xml_filename option).	
Name: kernel_logger.xml_filename	Type: parameter
Default: logger_output.xml	Data type: string
Description: Filename to keep logger xml output _(the option xml_file must be activated).	
5-leds-positions	
Name: 5-leds-positions.verbose	Type: parameter
Default: false	Data type: boolean
Valid: true, false	
Description: Enable/Disable verbosity.	

apu-dcr-stub	
Name: apu-dcr-stub.enable Default: true Valid: true, false	Type: parameter Data type: boolean
Description: Enable/Disable a lazy implementation of TLM 2.0 method interface.	
Name: apu-dcr-stub.verbose Default: false Valid: true, false	Type: parameter Data type: boolean
Description: Enable/Disable verbosity.	
bram	
Name: bram.org Default: 0x00000000fffc0000	Type: parameter Data type: unsigned 64-bit integer
Description: memory origin/base address.	
Name: bram.bytesize Default: 262144	Type: parameter Data type: unsigned 64-bit integer
Description: memory size in bytes.	
Name: bram.initial-byte-value Default: 0x00	Type: parameter Data type: unsigned 8-bit integer
Name: bram.cycle-time Default: 5 ns	Type: parameter Data type: sc_time
Description: memory cycle time.	
Name: bram.read-latency Default: 5 ns	Type: parameter Data type: sc_time
Description: memory read latency.	
Name: bram.write-latency Default: 0 s	Type: parameter Data type: sc_time
Description: memory write latency.	

Name: bram.verbose Default: false Valid: true, false Description: enable/disable verbosity.	Type: parameter Data type: boolean
capture-trigger-stub0	
Name: capture-trigger-stub0.cycle- ↔time Default: 5 ns	Type: parameter Data type: sc_time
Description: cycle time.	
Name: capture-trigger-stub0.nice- ↔time Default: 1 ms	Type: parameter Data type: sc_time
Description: nice time.	
Name: capture-trigger-stub0.verbose Default: false Valid: true, false	Type: parameter Data type: boolean
Description: Enable/Disable verbosity.	
Name: capture-trigger-stub0.enable Default: true Valid: true, false	Type: parameter Data type: boolean
Description: Enable/Disable.	
Name: capture-trigger-stub0.randomized ↔output Default: false Valid: true, false	Type: parameter Data type: boolean
Description: Enable/Disable randomized output.	
Name: capture-trigger-stub0.random- ↔seed Default: -123456	Type: parameter Data type: signed 32-bit integer
Description: Seed for the random generator.	

Name: capture-trigger-stub0.random- ↳period-min Default: 200	Type: parameter Data type: unsigned 32-bit integer
Description: Minimum period in cycles of randomized output.	
Name: capture-trigger-stub0.random- ↳period-max Default: 799	Type: parameter Data type: unsigned 32-bit integer
Description: Maximum period in cycles of randomized output.	
capture-trigger-stub1	
Name: capture-trigger-stub1.cycle- ↳time Default: 5 ns	Type: parameter Data type: sc_time
Description: cycle time.	
Name: capture-trigger-stub1.nice- ↳time Default: 1 ms	Type: parameter Data type: sc_time
Description: nice time.	
Name: capture-trigger-stub1.verbose Default: false Valid: true, false	Type: parameter Data type: boolean
Description: Enable/Disable verbosity.	
Name: capture-trigger-stub1.enable Default: true Valid: true, false	Type: parameter Data type: boolean
Description: Enable/Disable.	
Name: capture-trigger-stub1.randomized ↳output Default: false Valid: true, false	Type: parameter Data type: boolean
Description: Enable/Disable randomized output.	

Name: capture-trigger-stub1.random- ↳seed Default: -123456	Type: parameter Data type: signed 32-bit integer
Description: Seed for the random generator.	
Name: capture-trigger-stub1.random- ↳period-min Default: 200	Type: parameter Data type: unsigned 32-bit integer
Description: Minimum period in cycles of randomized output.	
Name: capture-trigger-stub1.random- ↳period-max Default: 799	Type: parameter Data type: unsigned 32-bit integer
Description: Maximum period in cycles of randomized output.	
cpu	
Name: cpu.cpu-cycle-time Default: 2500	Type: parameter Data type: unsigned 64-bit integer
Description: CPU cycle time in picoseconds.	
Name: cpu.voltage Default: 1000	Type: parameter Data type: unsigned 64-bit integer
Description: CPU voltage in mV.	
Name: cpu.max-inst Default: 18446744073709551615	Type: parameter Data type: unsigned 64-bit integer
Description: maximum number of instructions to simulate.	
Name: cpu.verbose-all Default: false Valid: true, false	Type: parameter Data type: boolean
Description: globally enable/disable verbosity.	
Name: cpu.verbose-setup	Type: parameter

Default: false Valid: true, false	Data type: boolean
Description: enable/disable verbosity while setup.	
Name: cpu.verbose-step Default: false Valid: true, false	Type: parameter Data type: boolean
Description: enable/disable verbosity when simulating an instruction.	
Name: cpu.verbose-itlb Default: false Valid: true, false	Type: parameter Data type: boolean
Description: enable/disable verbosity when accessing shadow instruction translation lookahead buffer.	
Name: cpu.verbose-dtlb Default: false Valid: true, false	Type: parameter Data type: boolean
Description: enable/disable verbosity when accessing shadow data translation lookahead buffer.	
Name: cpu.verbose-utlb Default: false Valid: true, false	Type: parameter Data type: boolean
Description: enable/disable verbosity when accessing unified translation lookahead buffer.	
Name: cpu.verbose-dl1 Default: false Valid: true, false	Type: parameter Data type: boolean
Description: enable/disable verbosity when accessing L1 data cache.	
Name: cpu.verbose-il1 Default: false Valid: true, false	Type: parameter Data type: boolean
Description: enable/disable verbosity when accessing L1 instruction cache.	
Name: cpu.verbose-load Default: false Valid: true, false	Type: parameter Data type: boolean
Description: enable/disable verbosity when simulating a load.	

Name: cpu.verbose-store Default: false Valid: true, false	Type: parameter Data type: boolean
Description: enable/disable verbosity when simulating a store.	
Name: cpu.verbose-read-memory Default: false Valid: true, false	Type: parameter Data type: boolean
Description: enable/disable verbosity when reading memory for a debug purpose.	
Name: cpu.verbose-write-memory Default: false Valid: true, false	Type: parameter Data type: boolean
Description: enable/disable verbosity when writing memory for a debug purpose.	
Name: cpu.verbose-exception Default: false Valid: true, false	Type: parameter Data type: boolean
Description: enable/disable verbosity when handling exceptions.	
Name: cpu.verbose-set-msr Default: false Valid: true, false	Type: parameter Data type: boolean
Description: enable/disable verbosity when setting MSR.	
Name: cpu.verbose-tlbwe Default: false Valid: true, false	Type: parameter Data type: boolean
Description: enable/disable verbosity when executing a tlbwe instruction.	
Name: cpu.enable-linux-printk-snooping Default: false Valid: true, false	Type: parameter Data type: boolean
Description: enable/disable linux printk buffer snooping.	
Name: cpu.enable-linux-syscall-snooping Default: false Valid: true, false	Type: parameter Data type: boolean
Description: enable/disable linux syscall snooping.	

Name: <code>cpu.trap-on-instruction-counter</code> Type: parameter Default: 18446744073709551615 Data type: unsigned 64-bit integer
Description: number of simulated instruction before trapping.
Name: <code>cpu.enable-trap-on-exception</code> Type: parameter Default: false Data type: boolean Valid: true, false
Description: enable/disable trap reporting on exception.
Name: <code>cpu.halt-on</code> Type: parameter Default: Data type: string
Description: Symbol or address where to stop simulation.
Name: <code>cpu.bus-cycle-time</code> Type: parameter Default: 5 ns Data type: sc_time
Description: bus cycle time.
Name: <code>cpu.ext-timer-cycle-time</code> Type: parameter Default: 5 ns Data type: sc_time
Description: external timer cycle time.
Name: <code>cpu.nice-time</code> Type: parameter Default: 200 ns Data type: sc_time
Description: maximum time between synchronizations.
Name: <code>cpu.ipc</code> Type: parameter Default: 2 Data type: double precision floating-point
Description: maximum instructions per cycle (should be ≤ 2.0).
Name: <code>cpu.enable-host-idle</code> Type: parameter Default: false Data type: boolean Valid: true, false

Description: Enable/Disable host idle periods when target is idle.	
Name: cpu.enable-dmi	Type: parameter
Default: true	Data type: boolean
Valid: true, false	
Description: Enable/Disable TLM 2.0 DMI (Direct Memory Access) to speed-up simulation.	
Name: cpu.debug-dmi	Type: parameter
Default: false	Data type: boolean
Valid: true, false	
Description: Enable/Disable debugging of DMI (Direct Memory Access).	
critical-input-interrupt-stub	
Name: critical-input-interrupt-stub. ↔enable	Type: parameter
Default: true	Data type: boolean
Valid: true, false	
Description: Enable/Disable a lazy implementation of TLM 2.0 method interface.	
Name: critical-input-interrupt-stub. ↔verbose	Type: parameter
Default: false	Data type: boolean
Valid: true, false	
Description: Enable/Disable verbosity.	
crossbar	
Name: crossbar.verbose	Type: parameter
Default: false	Data type: boolean
Valid: true, false	
Description: Enable/Disable verbosity.	
Name: crossbar.cycle-time	Type: parameter
Default: 5 ns	Data type: sc_time
Description: Enable/Disable verbosity.	
dcr-controller	
Name: dcr-controller.verbose	Type: parameter
Default: false	Data type: boolean
Valid: true, false	

Description: Enable/Disable verbosity.	
Name: dcr-controller.cycle-time	Type: parameter
Default: 5 ns	Data type: sc_time
Description: Cycle time.	
debugger	
Name: debugger.verbose	Type: parameter
Default: false	Data type: boolean
Valid: true, false	
Description: Enable/Disable verbosity.	
Name: debugger.dwarf-to-html-output- ↔directory	Type: parameter
Default:	Data type: string
Description: DWARF v2/v3 to HTML output directory.	
Name: debugger.dwarf-register-number- ↔mapping-filename	Type: parameter
Default: powerpc_eabi_gcc_dwarf_register_	Data type: string
↔number_mapping.xml	
Description: DWARF register number mapping filename.	
Name: debugger.parse-dwarf	Type: parameter
Default: true	Data type: boolean
Valid: true, false	
Description: Enable/Disable parsing of DWARF debugging informations.	
Name: debugger.debug-dwarf	Type: parameter
Default: false	Data type: boolean
Valid: true, false	
Description: Enable/Disable debugging of DWARF.	
dip-switches-8bit	
Name: dip-switches-8bit.verbose	Type: parameter
Default: false	Data type: boolean
Valid: true, false	

Description: Enable/Disable verbosity.	
Name: dip-switches-8bit.polling- ↔period	Type: parameter
Default: 10 ms	Data type: sc_time
Description: Polling period of host keyboard.	
dma0-dcr-stub	
Name: dma0-dcr-stub.enable	Type: parameter
Default: true	Data type: boolean
Valid: true, false	
Description: Enable/Disable a lazy implementation of TLM 2.0 method interface.	
Name: dma0-dcr-stub.verbose	Type: parameter
Default: false	Data type: boolean
Valid: true, false	
Description: Enable/Disable verbosity.	
dma1-dcr-stub	
Name: dma1-dcr-stub.enable	Type: parameter
Default: true	Data type: boolean
Valid: true, false	
Description: Enable/Disable a lazy implementation of TLM 2.0 method interface.	
Name: dma1-dcr-stub.verbose	Type: parameter
Default: false	Data type: boolean
Valid: true, false	
Description: Enable/Disable verbosity.	
dma2-dcr-stub	
Name: dma2-dcr-stub.enable	Type: parameter
Default: true	Data type: boolean
Valid: true, false	
Description: Enable/Disable a lazy implementation of TLM 2.0 method interface.	
Name: dma2-dcr-stub.verbose	Type: parameter
Default: false	Data type: boolean
Valid: true, false	
Description: Enable/Disable verbosity.	

dma3-dcr-stub	
Name: dma3-dcr-stub.enable	Type: parameter
Default: true	Data type: boolean
Valid: true, false	
Description: Enable/Disable a lazy implementation of TLM 2.0 method interface.	
Name: dma3-dcr-stub.verbose	Type: parameter
Default: false	Data type: boolean
Valid: true, false	
Description: Enable/Disable verbosity.	
external-slave-dcr-stub	
Name: external-slave-dcr-stub.enable	Type: parameter
Default: true	Data type: boolean
Valid: true, false	
Description: Enable/Disable a lazy implementation of TLM 2.0 method interface.	
Name: external-slave-dcr-stub.verbose	Type: parameter
Default: false	Data type: boolean
Valid: true, false	
Description: Enable/Disable verbosity.	
flash	
Name: flash.verbose	Type: parameter
Default: false	Data type: boolean
Valid: true, false	
Description: enable/disable verbosity.	
Name: flash.org	Type: parameter
Default: 0x00000000fc000000	Data type: unsigned 64-bit integer
Description: flash memory base address.	
Name: flash.bytesize	Type: parameter
Default: 33554432	Data type: unsigned 64-bit integer
Description: flash memory size in bytes.	
Name: flash.endian	Type: parameter
Default: little-endian	Data type: endianness

Valid: little-endian, big-endian	
Description: endianness of flash memory.	
Name: flash.sector-protect [0] Default: false Valid: true, false	Type: parameter Data type: boolean
Description: enable/disable sector write protection.	
Name: flash.sector-protect [1] Default: false Valid: true, false	Type: parameter Data type: boolean
Description: enable/disable sector write protection.	
Name: flash.sector-protect [2] Default: false Valid: true, false	Type: parameter Data type: boolean
Description: enable/disable sector write protection.	
Name: flash.sector-protect [3] Default: false Valid: true, false	Type: parameter Data type: boolean
Description: enable/disable sector write protection.	
Name: flash.sector-protect [4] Default: false Valid: true, false	Type: parameter Data type: boolean
Description: enable/disable sector write protection.	
Name: flash.sector-protect [5] Default: false Valid: true, false	Type: parameter Data type: boolean
Description: enable/disable sector write protection.	
Name: flash.sector-protect [6] Default: false Valid: true, false	Type: parameter Data type: boolean
Description: enable/disable sector write protection.	

Name: flash.sector-protect [7] Default: false Valid: true, false	Type: parameter Data type: boolean
Description: enable/disable sector write protection.	
Name: flash.sector-protect [8] Default: false Valid: true, false	Type: parameter Data type: boolean
Description: enable/disable sector write protection.	
Name: flash.sector-protect [9] Default: false Valid: true, false	Type: parameter Data type: boolean
Description: enable/disable sector write protection.	
Name: flash.sector-protect [10] Default: false Valid: true, false	Type: parameter Data type: boolean
Description: enable/disable sector write protection.	
Name: flash.sector-protect [11] Default: false Valid: true, false	Type: parameter Data type: boolean
Description: enable/disable sector write protection.	
Name: flash.sector-protect [12] Default: false Valid: true, false	Type: parameter Data type: boolean
Description: enable/disable sector write protection.	
Name: flash.sector-protect [13] Default: false Valid: true, false	Type: parameter Data type: boolean
Description: enable/disable sector write protection.	
Name: flash.sector-protect [14] Default: false Valid: true, false	Type: parameter Data type: boolean
Description: enable/disable sector write protection.	

Name: flash.sector-protect [15] Default: false Valid: true, false	Type: parameter Data type: boolean
Description: enable/disable sector write protection.	
Name: flash.sector-protect [16] Default: false Valid: true, false	Type: parameter Data type: boolean
Description: enable/disable sector write protection.	
Name: flash.sector-protect [17] Default: false Valid: true, false	Type: parameter Data type: boolean
Description: enable/disable sector write protection.	
Name: flash.sector-protect [18] Default: false Valid: true, false	Type: parameter Data type: boolean
Description: enable/disable sector write protection.	
Name: flash.sector-protect [19] Default: false Valid: true, false	Type: parameter Data type: boolean
Description: enable/disable sector write protection.	
Name: flash.sector-protect [20] Default: false Valid: true, false	Type: parameter Data type: boolean
Description: enable/disable sector write protection.	
Name: flash.sector-protect [21] Default: false Valid: true, false	Type: parameter Data type: boolean
Description: enable/disable sector write protection.	
Name: flash.sector-protect [22] Default: false Valid: true, false	Type: parameter Data type: boolean
Description: enable/disable sector write protection.	

Name: flash.sector-protect [23] Default: false Valid: true, false	Type: parameter Data type: boolean
Description: enable/disable sector write protection.	
Name: flash.sector-protect [24] Default: false Valid: true, false	Type: parameter Data type: boolean
Description: enable/disable sector write protection.	
Name: flash.sector-protect [25] Default: false Valid: true, false	Type: parameter Data type: boolean
Description: enable/disable sector write protection.	
Name: flash.sector-protect [26] Default: false Valid: true, false	Type: parameter Data type: boolean
Description: enable/disable sector write protection.	
Name: flash.sector-protect [27] Default: false Valid: true, false	Type: parameter Data type: boolean
Description: enable/disable sector write protection.	
Name: flash.sector-protect [28] Default: false Valid: true, false	Type: parameter Data type: boolean
Description: enable/disable sector write protection.	
Name: flash.sector-protect [29] Default: false Valid: true, false	Type: parameter Data type: boolean
Description: enable/disable sector write protection.	
Name: flash.sector-protect [30] Default: false Valid: true, false	Type: parameter Data type: boolean
Description: enable/disable sector write protection.	

Name: flash.sector-protect [31] Default: false Valid: true, false Description: enable/disable sector write protection.	Type: parameter Data type: boolean
Name: flash.sector-protect [32] Default: false Valid: true, false Description: enable/disable sector write protection.	Type: parameter Data type: boolean
Name: flash.sector-protect [33] Default: false Valid: true, false Description: enable/disable sector write protection.	Type: parameter Data type: boolean
Name: flash.sector-protect [34] Default: false Valid: true, false Description: enable/disable sector write protection.	Type: parameter Data type: boolean
Name: flash.sector-protect [35] Default: false Valid: true, false Description: enable/disable sector write protection.	Type: parameter Data type: boolean
Name: flash.sector-protect [36] Default: false Valid: true, false Description: enable/disable sector write protection.	Type: parameter Data type: boolean
Name: flash.sector-protect [37] Default: false Valid: true, false Description: enable/disable sector write protection.	Type: parameter Data type: boolean
Name: flash.sector-protect [38] Default: false Valid: true, false Description: enable/disable sector write protection.	Type: parameter Data type: boolean

Name: flash.sector-protect [39] Default: false Valid: true, false Description: enable/disable sector write protection.	Type: parameter Data type: boolean
Name: flash.sector-protect [40] Default: false Valid: true, false Description: enable/disable sector write protection.	Type: parameter Data type: boolean
Name: flash.sector-protect [41] Default: false Valid: true, false Description: enable/disable sector write protection.	Type: parameter Data type: boolean
Name: flash.sector-protect [42] Default: false Valid: true, false Description: enable/disable sector write protection.	Type: parameter Data type: boolean
Name: flash.sector-protect [43] Default: false Valid: true, false Description: enable/disable sector write protection.	Type: parameter Data type: boolean
Name: flash.sector-protect [44] Default: false Valid: true, false Description: enable/disable sector write protection.	Type: parameter Data type: boolean
Name: flash.sector-protect [45] Default: false Valid: true, false Description: enable/disable sector write protection.	Type: parameter Data type: boolean
Name: flash.sector-protect [46] Default: false Valid: true, false Description: enable/disable sector write protection.	Type: parameter Data type: boolean

Name: flash.sector-protect [47] Default: false Valid: true, false	Type: parameter Data type: boolean
Description: enable/disable sector write protection.	
Name: flash.sector-protect [48] Default: false Valid: true, false	Type: parameter Data type: boolean
Description: enable/disable sector write protection.	
Name: flash.sector-protect [49] Default: false Valid: true, false	Type: parameter Data type: boolean
Description: enable/disable sector write protection.	
Name: flash.sector-protect [50] Default: false Valid: true, false	Type: parameter Data type: boolean
Description: enable/disable sector write protection.	
Name: flash.sector-protect [51] Default: false Valid: true, false	Type: parameter Data type: boolean
Description: enable/disable sector write protection.	
Name: flash.sector-protect [52] Default: false Valid: true, false	Type: parameter Data type: boolean
Description: enable/disable sector write protection.	
Name: flash.sector-protect [53] Default: false Valid: true, false	Type: parameter Data type: boolean
Description: enable/disable sector write protection.	
Name: flash.sector-protect [54] Default: false Valid: true, false	Type: parameter Data type: boolean
Description: enable/disable sector write protection.	

Name: flash.sector-protect [55] Default: false Valid: true, false	Type: parameter Data type: boolean
Description: enable/disable sector write protection.	
Name: flash.sector-protect [56] Default: false Valid: true, false	Type: parameter Data type: boolean
Description: enable/disable sector write protection.	
Name: flash.sector-protect [57] Default: false Valid: true, false	Type: parameter Data type: boolean
Description: enable/disable sector write protection.	
Name: flash.sector-protect [58] Default: false Valid: true, false	Type: parameter Data type: boolean
Description: enable/disable sector write protection.	
Name: flash.sector-protect [59] Default: false Valid: true, false	Type: parameter Data type: boolean
Description: enable/disable sector write protection.	
Name: flash.sector-protect [60] Default: false Valid: true, false	Type: parameter Data type: boolean
Description: enable/disable sector write protection.	
Name: flash.sector-protect [61] Default: false Valid: true, false	Type: parameter Data type: boolean
Description: enable/disable sector write protection.	
Name: flash.sector-protect [62] Default: false Valid: true, false	Type: parameter Data type: boolean
Description: enable/disable sector write protection.	

Name: flash.sector-protect [63] Default: false Valid: true, false	Type: parameter Data type: boolean
Description: enable/disable sector write protection.	
Name: flash.sector-protect [64] Default: false Valid: true, false	Type: parameter Data type: boolean
Description: enable/disable sector write protection.	
Name: flash.sector-protect [65] Default: false Valid: true, false	Type: parameter Data type: boolean
Description: enable/disable sector write protection.	
Name: flash.sector-protect [66] Default: false Valid: true, false	Type: parameter Data type: boolean
Description: enable/disable sector write protection.	
Name: flash.sector-protect [67] Default: false Valid: true, false	Type: parameter Data type: boolean
Description: enable/disable sector write protection.	
Name: flash.sector-protect [68] Default: false Valid: true, false	Type: parameter Data type: boolean
Description: enable/disable sector write protection.	
Name: flash.sector-protect [69] Default: false Valid: true, false	Type: parameter Data type: boolean
Description: enable/disable sector write protection.	
Name: flash.sector-protect [70] Default: false Valid: true, false	Type: parameter Data type: boolean
Description: enable/disable sector write protection.	

Name: flash.sector-protect [71] Default: false Valid: true, false	Type: parameter Data type: boolean
Description: enable/disable sector write protection.	
Name: flash.sector-protect [72] Default: false Valid: true, false	Type: parameter Data type: boolean
Description: enable/disable sector write protection.	
Name: flash.sector-protect [73] Default: false Valid: true, false	Type: parameter Data type: boolean
Description: enable/disable sector write protection.	
Name: flash.sector-protect [74] Default: false Valid: true, false	Type: parameter Data type: boolean
Description: enable/disable sector write protection.	
Name: flash.sector-protect [75] Default: false Valid: true, false	Type: parameter Data type: boolean
Description: enable/disable sector write protection.	
Name: flash.sector-protect [76] Default: false Valid: true, false	Type: parameter Data type: boolean
Description: enable/disable sector write protection.	
Name: flash.sector-protect [77] Default: false Valid: true, false	Type: parameter Data type: boolean
Description: enable/disable sector write protection.	
Name: flash.sector-protect [78] Default: false Valid: true, false	Type: parameter Data type: boolean
Description: enable/disable sector write protection.	

Name: flash.sector-protect [79] Default: false Valid: true, false Description: enable/disable sector write protection.	Type: parameter Data type: boolean
Name: flash.sector-protect [80] Default: false Valid: true, false Description: enable/disable sector write protection.	Type: parameter Data type: boolean
Name: flash.sector-protect [81] Default: false Valid: true, false Description: enable/disable sector write protection.	Type: parameter Data type: boolean
Name: flash.sector-protect [82] Default: false Valid: true, false Description: enable/disable sector write protection.	Type: parameter Data type: boolean
Name: flash.sector-protect [83] Default: false Valid: true, false Description: enable/disable sector write protection.	Type: parameter Data type: boolean
Name: flash.sector-protect [84] Default: false Valid: true, false Description: enable/disable sector write protection.	Type: parameter Data type: boolean
Name: flash.sector-protect [85] Default: false Valid: true, false Description: enable/disable sector write protection.	Type: parameter Data type: boolean
Name: flash.sector-protect [86] Default: false Valid: true, false Description: enable/disable sector write protection.	Type: parameter Data type: boolean

Name: flash.sector-protect [87] Default: false Valid: true, false	Type: parameter Data type: boolean
Description: enable/disable sector write protection.	
Name: flash.sector-protect [88] Default: false Valid: true, false	Type: parameter Data type: boolean
Description: enable/disable sector write protection.	
Name: flash.sector-protect [89] Default: false Valid: true, false	Type: parameter Data type: boolean
Description: enable/disable sector write protection.	
Name: flash.sector-protect [90] Default: false Valid: true, false	Type: parameter Data type: boolean
Description: enable/disable sector write protection.	
Name: flash.sector-protect [91] Default: false Valid: true, false	Type: parameter Data type: boolean
Description: enable/disable sector write protection.	
Name: flash.sector-protect [92] Default: false Valid: true, false	Type: parameter Data type: boolean
Description: enable/disable sector write protection.	
Name: flash.sector-protect [93] Default: false Valid: true, false	Type: parameter Data type: boolean
Description: enable/disable sector write protection.	
Name: flash.sector-protect [94] Default: false Valid: true, false	Type: parameter Data type: boolean
Description: enable/disable sector write protection.	

Name: flash.sector-protect [95] Default: false Valid: true, false	Type: parameter Data type: boolean
Description: enable/disable sector write protection.	
Name: flash.sector-protect [96] Default: false Valid: true, false	Type: parameter Data type: boolean
Description: enable/disable sector write protection.	
Name: flash.sector-protect [97] Default: false Valid: true, false	Type: parameter Data type: boolean
Description: enable/disable sector write protection.	
Name: flash.sector-protect [98] Default: false Valid: true, false	Type: parameter Data type: boolean
Description: enable/disable sector write protection.	
Name: flash.sector-protect [99] Default: false Valid: true, false	Type: parameter Data type: boolean
Description: enable/disable sector write protection.	
Name: flash.sector-protect [100] Default: false Valid: true, false	Type: parameter Data type: boolean
Description: enable/disable sector write protection.	
Name: flash.sector-protect [101] Default: false Valid: true, false	Type: parameter Data type: boolean
Description: enable/disable sector write protection.	
Name: flash.sector-protect [102] Default: false Valid: true, false	Type: parameter Data type: boolean
Description: enable/disable sector write protection.	

Name: flash.sector-protect [103] Default: false Valid: true, false	Type: parameter Data type: boolean
Description: enable/disable sector write protection.	
Name: flash.sector-protect [104] Default: false Valid: true, false	Type: parameter Data type: boolean
Description: enable/disable sector write protection.	
Name: flash.sector-protect [105] Default: false Valid: true, false	Type: parameter Data type: boolean
Description: enable/disable sector write protection.	
Name: flash.sector-protect [106] Default: false Valid: true, false	Type: parameter Data type: boolean
Description: enable/disable sector write protection.	
Name: flash.sector-protect [107] Default: false Valid: true, false	Type: parameter Data type: boolean
Description: enable/disable sector write protection.	
Name: flash.sector-protect [108] Default: false Valid: true, false	Type: parameter Data type: boolean
Description: enable/disable sector write protection.	
Name: flash.sector-protect [109] Default: false Valid: true, false	Type: parameter Data type: boolean
Description: enable/disable sector write protection.	
Name: flash.sector-protect [110] Default: false Valid: true, false	Type: parameter Data type: boolean
Description: enable/disable sector write protection.	

Name: flash.sector-protect [111] Default: false Valid: true, false	Type: parameter Data type: boolean
Description: enable/disable sector write protection.	
Name: flash.sector-protect [112] Default: false Valid: true, false	Type: parameter Data type: boolean
Description: enable/disable sector write protection.	
Name: flash.sector-protect [113] Default: false Valid: true, false	Type: parameter Data type: boolean
Description: enable/disable sector write protection.	
Name: flash.sector-protect [114] Default: false Valid: true, false	Type: parameter Data type: boolean
Description: enable/disable sector write protection.	
Name: flash.sector-protect [115] Default: false Valid: true, false	Type: parameter Data type: boolean
Description: enable/disable sector write protection.	
Name: flash.sector-protect [116] Default: false Valid: true, false	Type: parameter Data type: boolean
Description: enable/disable sector write protection.	
Name: flash.sector-protect [117] Default: false Valid: true, false	Type: parameter Data type: boolean
Description: enable/disable sector write protection.	
Name: flash.sector-protect [118] Default: false Valid: true, false	Type: parameter Data type: boolean
Description: enable/disable sector write protection.	

Name: flash.sector-protect [119] Default: false Valid: true, false	Type: parameter Data type: boolean
Description: enable/disable sector write protection.	
Name: flash.sector-protect [120] Default: false Valid: true, false	Type: parameter Data type: boolean
Description: enable/disable sector write protection.	
Name: flash.sector-protect [121] Default: false Valid: true, false	Type: parameter Data type: boolean
Description: enable/disable sector write protection.	
Name: flash.sector-protect [122] Default: false Valid: true, false	Type: parameter Data type: boolean
Description: enable/disable sector write protection.	
Name: flash.sector-protect [123] Default: false Valid: true, false	Type: parameter Data type: boolean
Description: enable/disable sector write protection.	
Name: flash.sector-protect [124] Default: false Valid: true, false	Type: parameter Data type: boolean
Description: enable/disable sector write protection.	
Name: flash.sector-protect [125] Default: false Valid: true, false	Type: parameter Data type: boolean
Description: enable/disable sector write protection.	
Name: flash.sector-protect [126] Default: false Valid: true, false	Type: parameter Data type: boolean
Description: enable/disable sector write protection.	

Name: flash.sector-protect [127] Default: false Valid: true, false	Type: parameter Data type: boolean
Description: enable/disable sector write protection.	
Name: flash.sector-protect [128] Default: false Valid: true, false	Type: parameter Data type: boolean
Description: enable/disable sector write protection.	
Name: flash.sector-protect [129] Default: false Valid: true, false	Type: parameter Data type: boolean
Description: enable/disable sector write protection.	
Name: flash.sector-protect [130] Default: false Valid: true, false	Type: parameter Data type: boolean
Description: enable/disable sector write protection.	
Name: flash.sector-protect [131] Default: false Valid: true, false	Type: parameter Data type: boolean
Description: enable/disable sector write protection.	
Name: flash.sector-protect [132] Default: false Valid: true, false	Type: parameter Data type: boolean
Description: enable/disable sector write protection.	
Name: flash.sector-protect [133] Default: false Valid: true, false	Type: parameter Data type: boolean
Description: enable/disable sector write protection.	
Name: flash.sector-protect [134] Default: false Valid: true, false	Type: parameter Data type: boolean
Description: enable/disable sector write protection.	

Name: flash.sector-protect [135] Default: false Valid: true, false	Type: parameter Data type: boolean
Description: enable/disable sector write protection.	
Name: flash.sector-protect [136] Default: false Valid: true, false	Type: parameter Data type: boolean
Description: enable/disable sector write protection.	
Name: flash.sector-protect [137] Default: false Valid: true, false	Type: parameter Data type: boolean
Description: enable/disable sector write protection.	
Name: flash.sector-protect [138] Default: false Valid: true, false	Type: parameter Data type: boolean
Description: enable/disable sector write protection.	
Name: flash.sector-protect [139] Default: false Valid: true, false	Type: parameter Data type: boolean
Description: enable/disable sector write protection.	
Name: flash.sector-protect [140] Default: false Valid: true, false	Type: parameter Data type: boolean
Description: enable/disable sector write protection.	
Name: flash.sector-protect [141] Default: false Valid: true, false	Type: parameter Data type: boolean
Description: enable/disable sector write protection.	
Name: flash.sector-protect [142] Default: false Valid: true, false	Type: parameter Data type: boolean
Description: enable/disable sector write protection.	

Name: flash.sector-protect [143] Default: false Valid: true, false	Type: parameter Data type: boolean
Description: enable/disable sector write protection.	
Name: flash.sector-protect [144] Default: false Valid: true, false	Type: parameter Data type: boolean
Description: enable/disable sector write protection.	
Name: flash.sector-protect [145] Default: false Valid: true, false	Type: parameter Data type: boolean
Description: enable/disable sector write protection.	
Name: flash.sector-protect [146] Default: false Valid: true, false	Type: parameter Data type: boolean
Description: enable/disable sector write protection.	
Name: flash.sector-protect [147] Default: false Valid: true, false	Type: parameter Data type: boolean
Description: enable/disable sector write protection.	
Name: flash.sector-protect [148] Default: false Valid: true, false	Type: parameter Data type: boolean
Description: enable/disable sector write protection.	
Name: flash.sector-protect [149] Default: false Valid: true, false	Type: parameter Data type: boolean
Description: enable/disable sector write protection.	
Name: flash.sector-protect [150] Default: false Valid: true, false	Type: parameter Data type: boolean
Description: enable/disable sector write protection.	

Name: flash.sector-protect [151] Default: false Valid: true, false	Type: parameter Data type: boolean
Description: enable/disable sector write protection.	
Name: flash.sector-protect [152] Default: false Valid: true, false	Type: parameter Data type: boolean
Description: enable/disable sector write protection.	
Name: flash.sector-protect [153] Default: false Valid: true, false	Type: parameter Data type: boolean
Description: enable/disable sector write protection.	
Name: flash.sector-protect [154] Default: false Valid: true, false	Type: parameter Data type: boolean
Description: enable/disable sector write protection.	
Name: flash.sector-protect [155] Default: false Valid: true, false	Type: parameter Data type: boolean
Description: enable/disable sector write protection.	
Name: flash.sector-protect [156] Default: false Valid: true, false	Type: parameter Data type: boolean
Description: enable/disable sector write protection.	
Name: flash.sector-protect [157] Default: false Valid: true, false	Type: parameter Data type: boolean
Description: enable/disable sector write protection.	
Name: flash.sector-protect [158] Default: false Valid: true, false	Type: parameter Data type: boolean
Description: enable/disable sector write protection.	

Name: flash.sector-protect [159] Default: false Valid: true, false	Type: parameter Data type: boolean
Description: enable/disable sector write protection.	
Name: flash.sector-protect [160] Default: false Valid: true, false	Type: parameter Data type: boolean
Description: enable/disable sector write protection.	
Name: flash.sector-protect [161] Default: false Valid: true, false	Type: parameter Data type: boolean
Description: enable/disable sector write protection.	
Name: flash.sector-protect [162] Default: false Valid: true, false	Type: parameter Data type: boolean
Description: enable/disable sector write protection.	
Name: flash.sector-protect [163] Default: false Valid: true, false	Type: parameter Data type: boolean
Description: enable/disable sector write protection.	
Name: flash.sector-protect [164] Default: false Valid: true, false	Type: parameter Data type: boolean
Description: enable/disable sector write protection.	
Name: flash.sector-protect [165] Default: false Valid: true, false	Type: parameter Data type: boolean
Description: enable/disable sector write protection.	
Name: flash.sector-protect [166] Default: false Valid: true, false	Type: parameter Data type: boolean
Description: enable/disable sector write protection.	

Name: flash.sector-protect [167] Default: false Valid: true, false	Type: parameter Data type: boolean
Description: enable/disable sector write protection.	
Name: flash.sector-protect [168] Default: false Valid: true, false	Type: parameter Data type: boolean
Description: enable/disable sector write protection.	
Name: flash.sector-protect [169] Default: false Valid: true, false	Type: parameter Data type: boolean
Description: enable/disable sector write protection.	
Name: flash.sector-protect [170] Default: false Valid: true, false	Type: parameter Data type: boolean
Description: enable/disable sector write protection.	
Name: flash.sector-protect [171] Default: false Valid: true, false	Type: parameter Data type: boolean
Description: enable/disable sector write protection.	
Name: flash.sector-protect [172] Default: false Valid: true, false	Type: parameter Data type: boolean
Description: enable/disable sector write protection.	
Name: flash.sector-protect [173] Default: false Valid: true, false	Type: parameter Data type: boolean
Description: enable/disable sector write protection.	
Name: flash.sector-protect [174] Default: false Valid: true, false	Type: parameter Data type: boolean
Description: enable/disable sector write protection.	

Name: flash.sector-protect [175] Default: false Valid: true, false	Type: parameter Data type: boolean
Description: enable/disable sector write protection.	
Name: flash.sector-protect [176] Default: false Valid: true, false	Type: parameter Data type: boolean
Description: enable/disable sector write protection.	
Name: flash.sector-protect [177] Default: false Valid: true, false	Type: parameter Data type: boolean
Description: enable/disable sector write protection.	
Name: flash.sector-protect [178] Default: false Valid: true, false	Type: parameter Data type: boolean
Description: enable/disable sector write protection.	
Name: flash.sector-protect [179] Default: false Valid: true, false	Type: parameter Data type: boolean
Description: enable/disable sector write protection.	
Name: flash.sector-protect [180] Default: false Valid: true, false	Type: parameter Data type: boolean
Description: enable/disable sector write protection.	
Name: flash.sector-protect [181] Default: false Valid: true, false	Type: parameter Data type: boolean
Description: enable/disable sector write protection.	
Name: flash.sector-protect [182] Default: false Valid: true, false	Type: parameter Data type: boolean
Description: enable/disable sector write protection.	

Name: flash.sector-protect [183] Default: false Valid: true, false	Type: parameter Data type: boolean
Description: enable/disable sector write protection.	
Name: flash.sector-protect [184] Default: false Valid: true, false	Type: parameter Data type: boolean
Description: enable/disable sector write protection.	
Name: flash.sector-protect [185] Default: false Valid: true, false	Type: parameter Data type: boolean
Description: enable/disable sector write protection.	
Name: flash.sector-protect [186] Default: false Valid: true, false	Type: parameter Data type: boolean
Description: enable/disable sector write protection.	
Name: flash.sector-protect [187] Default: false Valid: true, false	Type: parameter Data type: boolean
Description: enable/disable sector write protection.	
Name: flash.sector-protect [188] Default: false Valid: true, false	Type: parameter Data type: boolean
Description: enable/disable sector write protection.	
Name: flash.sector-protect [189] Default: false Valid: true, false	Type: parameter Data type: boolean
Description: enable/disable sector write protection.	
Name: flash.sector-protect [190] Default: false Valid: true, false	Type: parameter Data type: boolean
Description: enable/disable sector write protection.	

Name: flash.sector-protect [191] Default: false Valid: true, false	Type: parameter Data type: boolean
Description: enable/disable sector write protection.	
Name: flash.sector-protect [192] Default: false Valid: true, false	Type: parameter Data type: boolean
Description: enable/disable sector write protection.	
Name: flash.sector-protect [193] Default: false Valid: true, false	Type: parameter Data type: boolean
Description: enable/disable sector write protection.	
Name: flash.sector-protect [194] Default: false Valid: true, false	Type: parameter Data type: boolean
Description: enable/disable sector write protection.	
Name: flash.sector-protect [195] Default: false Valid: true, false	Type: parameter Data type: boolean
Description: enable/disable sector write protection.	
Name: flash.sector-protect [196] Default: false Valid: true, false	Type: parameter Data type: boolean
Description: enable/disable sector write protection.	
Name: flash.sector-protect [197] Default: false Valid: true, false	Type: parameter Data type: boolean
Description: enable/disable sector write protection.	
Name: flash.sector-protect [198] Default: false Valid: true, false	Type: parameter Data type: boolean
Description: enable/disable sector write protection.	

Name: flash.sector-protect [199] Default: false Valid: true, false	Type: parameter Data type: boolean
Description: enable/disable sector write protection.	
Name: flash.sector-protect [200] Default: false Valid: true, false	Type: parameter Data type: boolean
Description: enable/disable sector write protection.	
Name: flash.sector-protect [201] Default: false Valid: true, false	Type: parameter Data type: boolean
Description: enable/disable sector write protection.	
Name: flash.sector-protect [202] Default: false Valid: true, false	Type: parameter Data type: boolean
Description: enable/disable sector write protection.	
Name: flash.sector-protect [203] Default: false Valid: true, false	Type: parameter Data type: boolean
Description: enable/disable sector write protection.	
Name: flash.sector-protect [204] Default: false Valid: true, false	Type: parameter Data type: boolean
Description: enable/disable sector write protection.	
Name: flash.sector-protect [205] Default: false Valid: true, false	Type: parameter Data type: boolean
Description: enable/disable sector write protection.	
Name: flash.sector-protect [206] Default: false Valid: true, false	Type: parameter Data type: boolean
Description: enable/disable sector write protection.	

Name: flash.sector-protect [207] Default: false Valid: true, false	Type: parameter Data type: boolean
Description: enable/disable sector write protection.	
Name: flash.sector-protect [208] Default: false Valid: true, false	Type: parameter Data type: boolean
Description: enable/disable sector write protection.	
Name: flash.sector-protect [209] Default: false Valid: true, false	Type: parameter Data type: boolean
Description: enable/disable sector write protection.	
Name: flash.sector-protect [210] Default: false Valid: true, false	Type: parameter Data type: boolean
Description: enable/disable sector write protection.	
Name: flash.sector-protect [211] Default: false Valid: true, false	Type: parameter Data type: boolean
Description: enable/disable sector write protection.	
Name: flash.sector-protect [212] Default: false Valid: true, false	Type: parameter Data type: boolean
Description: enable/disable sector write protection.	
Name: flash.sector-protect [213] Default: false Valid: true, false	Type: parameter Data type: boolean
Description: enable/disable sector write protection.	
Name: flash.sector-protect [214] Default: false Valid: true, false	Type: parameter Data type: boolean
Description: enable/disable sector write protection.	

Name: flash.sector-protect [215] Default: false Valid: true, false	Type: parameter Data type: boolean
Description: enable/disable sector write protection.	
Name: flash.sector-protect [216] Default: false Valid: true, false	Type: parameter Data type: boolean
Description: enable/disable sector write protection.	
Name: flash.sector-protect [217] Default: false Valid: true, false	Type: parameter Data type: boolean
Description: enable/disable sector write protection.	
Name: flash.sector-protect [218] Default: false Valid: true, false	Type: parameter Data type: boolean
Description: enable/disable sector write protection.	
Name: flash.sector-protect [219] Default: false Valid: true, false	Type: parameter Data type: boolean
Description: enable/disable sector write protection.	
Name: flash.sector-protect [220] Default: false Valid: true, false	Type: parameter Data type: boolean
Description: enable/disable sector write protection.	
Name: flash.sector-protect [221] Default: false Valid: true, false	Type: parameter Data type: boolean
Description: enable/disable sector write protection.	
Name: flash.sector-protect [222] Default: false Valid: true, false	Type: parameter Data type: boolean
Description: enable/disable sector write protection.	

Name: flash.sector-protect [223] Default: false Valid: true, false	Type: parameter Data type: boolean
Description: enable/disable sector write protection.	
Name: flash.sector-protect [224] Default: false Valid: true, false	Type: parameter Data type: boolean
Description: enable/disable sector write protection.	
Name: flash.sector-protect [225] Default: false Valid: true, false	Type: parameter Data type: boolean
Description: enable/disable sector write protection.	
Name: flash.sector-protect [226] Default: false Valid: true, false	Type: parameter Data type: boolean
Description: enable/disable sector write protection.	
Name: flash.sector-protect [227] Default: false Valid: true, false	Type: parameter Data type: boolean
Description: enable/disable sector write protection.	
Name: flash.sector-protect [228] Default: false Valid: true, false	Type: parameter Data type: boolean
Description: enable/disable sector write protection.	
Name: flash.sector-protect [229] Default: false Valid: true, false	Type: parameter Data type: boolean
Description: enable/disable sector write protection.	
Name: flash.sector-protect [230] Default: false Valid: true, false	Type: parameter Data type: boolean
Description: enable/disable sector write protection.	

Name: flash.sector-protect [231] Default: false Valid: true, false	Type: parameter Data type: boolean
Description: enable/disable sector write protection.	
Name: flash.sector-protect [232] Default: false Valid: true, false	Type: parameter Data type: boolean
Description: enable/disable sector write protection.	
Name: flash.sector-protect [233] Default: false Valid: true, false	Type: parameter Data type: boolean
Description: enable/disable sector write protection.	
Name: flash.sector-protect [234] Default: false Valid: true, false	Type: parameter Data type: boolean
Description: enable/disable sector write protection.	
Name: flash.sector-protect [235] Default: false Valid: true, false	Type: parameter Data type: boolean
Description: enable/disable sector write protection.	
Name: flash.sector-protect [236] Default: false Valid: true, false	Type: parameter Data type: boolean
Description: enable/disable sector write protection.	
Name: flash.sector-protect [237] Default: false Valid: true, false	Type: parameter Data type: boolean
Description: enable/disable sector write protection.	
Name: flash.sector-protect [238] Default: false Valid: true, false	Type: parameter Data type: boolean
Description: enable/disable sector write protection.	

Name: flash.sector-protect [239] Default: false Valid: true, false	Type: parameter Data type: boolean
Description: enable/disable sector write protection.	
Name: flash.sector-protect [240] Default: false Valid: true, false	Type: parameter Data type: boolean
Description: enable/disable sector write protection.	
Name: flash.sector-protect [241] Default: false Valid: true, false	Type: parameter Data type: boolean
Description: enable/disable sector write protection.	
Name: flash.sector-protect [242] Default: false Valid: true, false	Type: parameter Data type: boolean
Description: enable/disable sector write protection.	
Name: flash.sector-protect [243] Default: false Valid: true, false	Type: parameter Data type: boolean
Description: enable/disable sector write protection.	
Name: flash.sector-protect [244] Default: false Valid: true, false	Type: parameter Data type: boolean
Description: enable/disable sector write protection.	
Name: flash.sector-protect [245] Default: false Valid: true, false	Type: parameter Data type: boolean
Description: enable/disable sector write protection.	
Name: flash.sector-protect [246] Default: false Valid: true, false	Type: parameter Data type: boolean
Description: enable/disable sector write protection.	

Name: flash.sector-protect [247] Default: false Valid: true, false	Type: parameter Data type: boolean
Description: enable/disable sector write protection.	
Name: flash.sector-protect [248] Default: false Valid: true, false	Type: parameter Data type: boolean
Description: enable/disable sector write protection.	
Name: flash.sector-protect [249] Default: false Valid: true, false	Type: parameter Data type: boolean
Description: enable/disable sector write protection.	
Name: flash.sector-protect [250] Default: false Valid: true, false	Type: parameter Data type: boolean
Description: enable/disable sector write protection.	
Name: flash.sector-protect [251] Default: false Valid: true, false	Type: parameter Data type: boolean
Description: enable/disable sector write protection.	
Name: flash.sector-protect [252] Default: false Valid: true, false	Type: parameter Data type: boolean
Description: enable/disable sector write protection.	
Name: flash.sector-protect [253] Default: false Valid: true, false	Type: parameter Data type: boolean
Description: enable/disable sector write protection.	
Name: flash.sector-protect [254] Default: false Valid: true, false	Type: parameter Data type: boolean
Description: enable/disable sector write protection.	

Name: flash.sector-protect [255] Default: false Valid: true, false	Type: parameter Data type: boolean
Description: enable/disable sector write protection.	
Name: flash.fsm-to-graphviz-output- ↪filename Default:	Type: parameter Data type: string
Description: FSM (finite state machine) to Graphviz output filename.	
Name: flash.cycle-time Default: 5 ns	Type: parameter Data type: sc_time
Description: Cycle time.	
gdb-server	
Name: gdb-server.memory-atom-size Default: 0x00000001	Type: parameter Data type: unsigned 32-bit integer
Description: size of the smallest addressable element in memory.	
Name: gdb-server.tcp-port Default: 0	Type: parameter Data type: signed 32-bit integer
Description: TCP/IP port to listen waiting for a GDB client connection.	
Name: gdb-server.architecture-description- ↪filename Default: gdb_powerpc.xml	Type: parameter Data type: string
Description: filename of a XML description of the connected processor.	
Name: gdb-server.verbose Default: false Valid: true, false	Type: parameter Data type: boolean
Description: Enable/Disable verbosity.	
generate-out-stub0	
Name: generate-out-stub0.enable	Type: parameter

Default: true	Data type: boolean
Valid: true, false	
Description: Enable/Disable a lazy implementation of TLM 2.0 method interface.	
Name: generate-out-stub0.verbose	Type: parameter
Default: false	Data type: boolean
Valid: true, false	
Description: Enable/Disable verbosity.	
generate-out-stub1	
Name: generate-out-stub1.enable	Type: parameter
Default: true	Data type: boolean
Valid: true, false	
Description: Enable/Disable a lazy implementation of TLM 2.0 method interface.	
Name: generate-out-stub1.verbose	Type: parameter
Default: false	Data type: boolean
Valid: true, false	
Description: Enable/Disable verbosity.	
gpio-5-leds-positions	
Name: gpio-5-leds-positions.verbose	Type: parameter
Default: false	Data type: boolean
Valid: true, false	
Description: Enable/Disable verbosity.	
Name: gpio-5-leds-positions.c-baseaddr	Type: parameter
Default: 0x0000000081420000	Data type: unsigned 64-bit integer
Description: Base address (C_BASEADDR design parameter).	
Name: gpio-5-leds-positions.c-highaddr	Type: parameter
Default: 0x000000008142ffff	Data type: unsigned 64-bit integer
Description: High address (C_HIGHADDR design parameter).	
Name: gpio-5-leds-positions.cycle- ↔time	Type: parameter
Default: 5 ns	Data type: sc_time

Description: Cycle time.	
gpio-dip-switches-8bit	
Name: gpio-dip-switches-8bit.verbose	Type: parameter
Default: false	Data type: boolean
Valid: true, false	
Description: Enable/Disable verbosity.	
Name: gpio-dip-switches-8bit.c-baseaddr	Type: parameter
Default: 0x0000000081460000	Data type: unsigned 64-bit integer
Description: Base address (C_BASEADDR design parameter).	
Name: gpio-dip-switches-8bit.c-highaddr	Type: parameter
Default: 0x000000008146ffff	Data type: unsigned 64-bit integer
Description: High address (C_HIGHADDR design parameter).	
Name: gpio-dip-switches-8bit.cycle- ↔time	Type: parameter
Default: 5 ns	Data type: sc_time
Description: Cycle time.	
gpio-leds-8bit	
Name: gpio-leds-8bit.verbose	Type: parameter
Default: false	Data type: boolean
Valid: true, false	
Description: Enable/Disable verbosity.	
Name: gpio-leds-8bit.c-baseaddr	Type: parameter
Default: 0x0000000081400000	Data type: unsigned 64-bit integer
Description: Base address (C_BASEADDR design parameter).	
Name: gpio-leds-8bit.c-highaddr	Type: parameter
Default: 0x000000008140ffff	Data type: unsigned 64-bit integer
Description: High address (C_HIGHADDR design parameter).	

Name: gpio-leds-8bit.cycle-time Default: 5 ns	Type: parameter Data type: sc_time
Description: Cycle time.	
gpio-push-buttons-5bit	
Name: gpio-push-buttons-5bit.verbose Default: false Valid: true, false	Type: parameter Data type: boolean
Description: Enable/Disable verbosity.	
Name: gpio-push-buttons-5bit.c-baseaddr Default: 0x0000000081440000	Type: parameter Data type: unsigned 64-bit integer
Description: Base address (C_BASEADDR design parameter).	
Name: gpio-push-buttons-5bit.c-highaddr Default: 0x000000008144ffff	Type: parameter Data type: unsigned 64-bit integer
Description: High address (C_HIGHADDR design parameter).	
Name: gpio-push-buttons-5bit.cycle- ↔time Default: 5 ns	Type: parameter Data type: sc_time
Description: Cycle time.	
inline-debugger	
Name: inline-debugger.memory-atom- ↔size Default: 0x00000001	Type: parameter Data type: unsigned 32-bit integer
Description: size of the smallest addressable element in memory.	
Name: inline-debugger.search-path Default:	Type: parameter Data type: string
Description: Search path for source (separated by ';').	
Name: inline-debugger.init-macro	Type: parameter

Default:	Data type: string
Description: path to initial macro to run when debugger starts.	
Name: inline-debugger.output	Type: parameter
Default:	Data type: string
Description: path to output file where to redirect the debugger outputs.	
input-interrupt-stub0	
Name: input-interrupt-stub0.enable	Type: parameter
Default: true	Data type: boolean
Valid: true, false	
Description: Enable/Disable a lazy implementation of TLM 2.0 method interface.	
Name: input-interrupt-stub0.verbose	Type: parameter
Default: false	Data type: boolean
Valid: true, false	
Description: Enable/Disable verbosity.	
input-interrupt-stub1	
Name: input-interrupt-stub1.enable	Type: parameter
Default: true	Data type: boolean
Valid: true, false	
Description: Enable/Disable a lazy implementation of TLM 2.0 method interface.	
Name: input-interrupt-stub1.verbose	Type: parameter
Default: false	Data type: boolean
Valid: true, false	
Description: Enable/Disable verbosity.	
input-interrupt-stub10	
Name: input-interrupt-stub10.enable	Type: parameter
Default: true	Data type: boolean
Valid: true, false	
Description: Enable/Disable a lazy implementation of TLM 2.0 method interface.	
Name: input-interrupt-stub10.verbose	Type: parameter
Default: false	Data type: boolean
Valid: true, false	

Description:

Enable/Disable verbosity.

input-interrupt-stub11

Name: input-interrupt-stub11.enable **Type:** parameter
Default: true **Data type:** boolean
Valid: true, false

Description:

Enable/Disable a lazy implementation of TLM 2.0 method interface.

Name: input-interrupt-stub11.verbose **Type:** parameter
Default: false **Data type:** boolean
Valid: true, false

Description:

Enable/Disable verbosity.

input-interrupt-stub12

Name: input-interrupt-stub12.enable **Type:** parameter
Default: true **Data type:** boolean
Valid: true, false

Description:

Enable/Disable a lazy implementation of TLM 2.0 method interface.

Name: input-interrupt-stub12.verbose **Type:** parameter
Default: false **Data type:** boolean
Valid: true, false

Description:

Enable/Disable verbosity.

input-interrupt-stub13

Name: input-interrupt-stub13.enable **Type:** parameter
Default: true **Data type:** boolean
Valid: true, false

Description:

Enable/Disable a lazy implementation of TLM 2.0 method interface.

Name: input-interrupt-stub13.verbose **Type:** parameter
Default: false **Data type:** boolean
Valid: true, false

Description:

Enable/Disable verbosity.

input-interrupt-stub14

Name: input-interrupt-stub14.enable **Type:** parameter
Default: true **Data type:** boolean
Valid: true, false

Description: Enable/Disable a lazy implementation of TLM 2.0 method interface.	
Name: input-interrupt-stub14.verbose	Type: parameter
Default: false	Data type: boolean
Valid: true, false	
Description: Enable/Disable verbosity.	
input-interrupt-stub15	
Name: input-interrupt-stub15.enable	Type: parameter
Default: true	Data type: boolean
Valid: true, false	
Description: Enable/Disable a lazy implementation of TLM 2.0 method interface.	
Name: input-interrupt-stub15.verbose	Type: parameter
Default: false	Data type: boolean
Valid: true, false	
Description: Enable/Disable verbosity.	
input-interrupt-stub16	
Name: input-interrupt-stub16.enable	Type: parameter
Default: true	Data type: boolean
Valid: true, false	
Description: Enable/Disable a lazy implementation of TLM 2.0 method interface.	
Name: input-interrupt-stub16.verbose	Type: parameter
Default: false	Data type: boolean
Valid: true, false	
Description: Enable/Disable verbosity.	
input-interrupt-stub17	
Name: input-interrupt-stub17.enable	Type: parameter
Default: true	Data type: boolean
Valid: true, false	
Description: Enable/Disable a lazy implementation of TLM 2.0 method interface.	
Name: input-interrupt-stub17.verbose	Type: parameter
Default: false	Data type: boolean
Valid: true, false	
Description: Enable/Disable verbosity.	

input-interrupt-stub18	
Name: input-interrupt-stub18.enable	Type: parameter
Default: true	Data type: boolean
Valid: true, false	
Description: Enable/Disable a lazy implementation of TLM 2.0 method interface.	
Name: input-interrupt-stub18.verbose	Type: parameter
Default: false	Data type: boolean
Valid: true, false	
Description: Enable/Disable verbosity.	
input-interrupt-stub19	
Name: input-interrupt-stub19.enable	Type: parameter
Default: true	Data type: boolean
Valid: true, false	
Description: Enable/Disable a lazy implementation of TLM 2.0 method interface.	
Name: input-interrupt-stub19.verbose	Type: parameter
Default: false	Data type: boolean
Valid: true, false	
Description: Enable/Disable verbosity.	
input-interrupt-stub20	
Name: input-interrupt-stub20.enable	Type: parameter
Default: true	Data type: boolean
Valid: true, false	
Description: Enable/Disable a lazy implementation of TLM 2.0 method interface.	
Name: input-interrupt-stub20.verbose	Type: parameter
Default: false	Data type: boolean
Valid: true, false	
Description: Enable/Disable verbosity.	
input-interrupt-stub21	
Name: input-interrupt-stub21.enable	Type: parameter
Default: true	Data type: boolean
Valid: true, false	
Description: Enable/Disable a lazy implementation of TLM 2.0 method interface.	

Name: input-interrupt-stub21.verbose Default: false Valid: true, false Description: Enable/Disable verbosity.	Type: parameter Data type: boolean
input-interrupt-stub22	
Name: input-interrupt-stub22.enable Default: true Valid: true, false Description: Enable/Disable a lazy implementation of TLM 2.0 method interface.	Type: parameter Data type: boolean
Name: input-interrupt-stub22.verbose Default: false Valid: true, false Description: Enable/Disable verbosity.	Type: parameter Data type: boolean
input-interrupt-stub23	
Name: input-interrupt-stub23.enable Default: true Valid: true, false Description: Enable/Disable a lazy implementation of TLM 2.0 method interface.	Type: parameter Data type: boolean
Name: input-interrupt-stub23.verbose Default: false Valid: true, false Description: Enable/Disable verbosity.	Type: parameter Data type: boolean
input-interrupt-stub24	
Name: input-interrupt-stub24.enable Default: true Valid: true, false Description: Enable/Disable a lazy implementation of TLM 2.0 method interface.	Type: parameter Data type: boolean
Name: input-interrupt-stub24.verbose Default: false Valid: true, false Description: Enable/Disable verbosity.	Type: parameter Data type: boolean
input-interrupt-stub25	
Name: input-interrupt-stub25.enable 	Type: parameter

Default: true	Data type: boolean
Valid: true, false	
Description: Enable/Disable a lazy implementation of TLM 2.0 method interface.	
Name: input-interrupt-stub25.verbose	Type: parameter
Default: false	Data type: boolean
Valid: true, false	
Description: Enable/Disable verbosity.	
input-interrupt-stub26	
Name: input-interrupt-stub26.enable	Type: parameter
Default: true	Data type: boolean
Valid: true, false	
Description: Enable/Disable a lazy implementation of TLM 2.0 method interface.	
Name: input-interrupt-stub26.verbose	Type: parameter
Default: false	Data type: boolean
Valid: true, false	
Description: Enable/Disable verbosity.	
input-interrupt-stub27	
Name: input-interrupt-stub27.enable	Type: parameter
Default: true	Data type: boolean
Valid: true, false	
Description: Enable/Disable a lazy implementation of TLM 2.0 method interface.	
Name: input-interrupt-stub27.verbose	Type: parameter
Default: false	Data type: boolean
Valid: true, false	
Description: Enable/Disable verbosity.	
input-interrupt-stub28	
Name: input-interrupt-stub28.enable	Type: parameter
Default: true	Data type: boolean
Valid: true, false	
Description: Enable/Disable a lazy implementation of TLM 2.0 method interface.	
Name: input-interrupt-stub28.verbose	Type: parameter
Default: false	Data type: boolean
Valid: true, false	

Description:

Enable/Disable verbosity.

input-interrupt-stub29

Name: input-interrupt-stub29.enable **Type:** parameter
Default: true **Data type:** boolean
Valid: true, false

Description:

Enable/Disable a lazy implementation of TLM 2.0 method interface.

Name: input-interrupt-stub29.verbose **Type:** parameter
Default: false **Data type:** boolean
Valid: true, false

Description:

Enable/Disable verbosity.

input-interrupt-stub30

Name: input-interrupt-stub30.enable **Type:** parameter
Default: true **Data type:** boolean
Valid: true, false

Description:

Enable/Disable a lazy implementation of TLM 2.0 method interface.

Name: input-interrupt-stub30.verbose **Type:** parameter
Default: false **Data type:** boolean
Valid: true, false

Description:

Enable/Disable verbosity.

input-interrupt-stub31

Name: input-interrupt-stub31.enable **Type:** parameter
Default: true **Data type:** boolean
Valid: true, false

Description:

Enable/Disable a lazy implementation of TLM 2.0 method interface.

Name: input-interrupt-stub31.verbose **Type:** parameter
Default: false **Data type:** boolean
Valid: true, false

Description:

Enable/Disable verbosity.

input-interrupt-stub4

Name: input-interrupt-stub4.enable **Type:** parameter
Default: true **Data type:** boolean
Valid: true, false

Description: Enable/Disable a lazy implementation of TLM 2.0 method interface.	
Name: input-interrupt-stub4.verbose	Type: parameter
Default: false	Data type: boolean
Valid: true, false	
Description: Enable/Disable verbosity.	
input-interrupt-stub5	
Name: input-interrupt-stub5.enable	Type: parameter
Default: true	Data type: boolean
Valid: true, false	
Description: Enable/Disable a lazy implementation of TLM 2.0 method interface.	
Name: input-interrupt-stub5.verbose	Type: parameter
Default: false	Data type: boolean
Valid: true, false	
Description: Enable/Disable verbosity.	
input-interrupt-stub6	
Name: input-interrupt-stub6.enable	Type: parameter
Default: true	Data type: boolean
Valid: true, false	
Description: Enable/Disable a lazy implementation of TLM 2.0 method interface.	
Name: input-interrupt-stub6.verbose	Type: parameter
Default: false	Data type: boolean
Valid: true, false	
Description: Enable/Disable verbosity.	
input-interrupt-stub9	
Name: input-interrupt-stub9.enable	Type: parameter
Default: true	Data type: boolean
Valid: true, false	
Description: Enable/Disable a lazy implementation of TLM 2.0 method interface.	
Name: input-interrupt-stub9.verbose	Type: parameter
Default: false	Data type: boolean
Valid: true, false	
Description: Enable/Disable verbosity.	

intc	
Name: intc.verbose Default: false Valid: true, false	Type: parameter Data type: boolean
Description: Enable/Disable verbosity.	
Name: intc.c-baseaddr Default: 0x0000000081800000	Type: parameter Data type: unsigned 64-bit integer
Description: Base address (C_BASEADDR design parameter).	
Name: intc.c-highaddr Default: 0x000000008180ffff	Type: parameter Data type: unsigned 64-bit integer
Description: High address (C_HIGHADDR design parameter).	
Name: intc.cycle-time Default: 5 ns	Type: parameter Data type: sc_time
Description: Cycle time.	
leds-8bit	
Name: leds-8bit.verbose Default: false Valid: true, false	Type: parameter Data type: boolean
Description: Enable/Disable verbosity.	
loader	
Name: loader.verbose Default: false Valid: true, false	Type: parameter Data type: boolean
Description: Enable/Disable verbosity.	
Name: loader.verbose-parser Default: false Valid: true, false	Type: parameter Data type: boolean
Description: Enable/Disable verbosity of parser.	
Name: loader.filename Default:	Type: parameter Data type: string

<p>Description: List of files to load. Syntax: [[filename=]<filename1>[:[format=]<format1>]][,[filename=]<filename2>[:[form (e.g. boot.bin:raw,app.elf).</p>	
loader.memory-mapper	
<p>Name: loader.memory-mapper.verbose Default: false Valid: true, false</p>	<p>Type: parameter Data type: boolean</p>
<p>Description: Enable/Disable verbosity.</p>	
<p>Name: loader.memory-mapper.verbose- ↔parser Default: false Valid: true, false</p>	<p>Type: parameter Data type: boolean</p>
<p>Description: Enable/Disable verbosity of parser.</p>	
<p>Name: loader.memory-mapper.mapping Default: ram-effective-to-physical- ↔address-translator:0x0-0xffffffff, bram- ↔effective-to-physical-address- ↔translator:0xffc0000-0xffffffff, flash- ↔effective-to-physical-address- ↔translator:0xfc00000-0xfdffffff</p>	<p>Type: parameter Data type: string</p>
<p>Description: Memory mapping. Syntax: [[(memory=)<memory1>[:[range=]<low1- high1>]][,(memory=)<memory2>[:[range=]<low2-high2>]]... (e.g. ram:0x0- 0x00fff,rom:0xff0000-0xffff).</p>	
master1-dcr-stub	
<p>Name: master1-dcr-stub.enable Default: true Valid: true, false</p>	<p>Type: parameter Data type: boolean</p>
<p>Description: Enable/Disable a lazy implementation of TLM 2.0 method interface.</p>	
<p>Name: master1-dcr-stub.verbose Default: false Valid: true, false</p>	<p>Type: parameter Data type: boolean</p>
<p>Description: Enable/Disable verbosity.</p>	
mci	
<p>Name: mci.verbose</p>	<p>Type: parameter</p>

Default: false Valid: true, false Description: Enable/Disable verbosity.	Data type: boolean
Name: mci.cycle-time Default: 5 ns	Type: parameter Data type: sc_time
Description: Enable/Disable verbosity.	
mplb	
Name: mplb.cycle_time Default: 5 ns	Type: parameter Data type: sc_time
Description: Time to process a request/response by the router.	
Name: mplb.port_buffer_size Default: 0	Type: parameter Data type: unsigned 32-bit integer
Description: Defines the size of the buffer for incoming requests in each of the input ports (0 = infinite).	
Name: mplb.mapping_0 Default: range_start="0x81800000" ↔range_end="0x8180ffff" output_ ↔port="0" translation="0x81800000"	Type: parameter Data type: unisim::component::tlm2::interconnect: ↔:generic_router::Mapping
Description: Defined a mapping of the router with format "[range_start]", "[range_end]", "[outport_index]" where [range_start], [range_end] and [outport_index] are to be replaced with the initial address, end address (= range_start + range_size - 1) and the output port index respectively.	
Name: mplb.mapping_1 Default: range_start="0x83c00000" ↔range_end="0x83c0ffff" output_ ↔port="1" translation="0x83c00000"	Type: parameter Data type: unisim::component::tlm2::interconnect: ↔:generic_router::Mapping
Description: Defined a mapping of the router with format "[range_start]", "[range_end]", "[outport_index]" where [range_start], [range_end] and [outport_index] are to be replaced with the initial address, end address (= range_start + range_size - 1) and the output port index respectively.	

<p>Name: mplb.mapping_2</p> <p>Default: range_start="0xfc000000" ↔range_end="0xfdffffff" output_ ↔port="2" translation="0xfc000000"</p> <p>Description: Defined a mapping of the router with format "[range_start]", "[range_end]", "[output_index]" where [range_start], [range_end] and [output_index] are to be replaced with the initial address, end address (= range_start + range_size - 1) and the output port index respectively.</p>	<p>Type: parameter</p> <p>Data type: unisim::component::t1m2::interconnect: ↔:generic_router::Mapping</p>
<p>Name: mplb.mapping_3</p> <p>Default: range_start="0xfffc0000" ↔range_end="0xffffffff" output_ ↔port="3" translation="0xfffc0000"</p> <p>Description: Defined a mapping of the router with format "[range_start]", "[range_end]", "[output_index]" where [range_start], [range_end] and [output_index] are to be replaced with the initial address, end address (= range_start + range_size - 1) and the output port index respectively.</p>	<p>Type: parameter</p> <p>Data type: unisim::component::t1m2::interconnect: ↔:generic_router::Mapping</p>
<p>Name: mplb.mapping_4</p> <p>Default: range_start="0x84000000" ↔range_end="0x840ffff" output_ ↔port="4" translation="0x84000000"</p> <p>Description: Defined a mapping of the router with format "[range_start]", "[range_end]", "[output_index]" where [range_start], [range_end] and [output_index] are to be replaced with the initial address, end address (= range_start + range_size - 1) and the output port index respectively.</p>	<p>Type: parameter</p> <p>Data type: unisim::component::t1m2::interconnect: ↔:generic_router::Mapping</p>
<p>Name: mplb.mapping_5</p> <p>Default: range_start="0x81460000" ↔range_end="0x8146ffff" output_ ↔port="5" translation="0x81460000"</p> <p>Description: Defined a mapping of the router with format "[range_start]", "[range_end]", "[output_index]" where [range_start], [range_end] and [output_index] are to be replaced with the initial address, end address (= range_start + range_size - 1) and the output port index respectively.</p>	<p>Type: parameter</p> <p>Data type: unisim::component::t1m2::interconnect: ↔:generic_router::Mapping</p>

<p>Name: mplb.mapping_6</p> <p>Default: range_start="0x81400000" ↔range_end="0x8140ffff" output_ ↔port="6" translation="0x81400000"</p> <p>Description: Defined a mapping of the router with format "[range_start]", "[range_end]", "[outport_index]" where [range_start], [range_end] and [outport_index] are to be replaced with the initial address, end address (= range_start + range_size - 1) and the output port index respectively.</p>	<p>Type: parameter</p> <p>Data type: unisim::component::t1m2::interconnect: ↔:generic_router::Mapping</p>
<p>Name: mplb.mapping_7</p> <p>Default: range_start="0x81420000" ↔range_end="0x8142ffff" output_ ↔port="7" translation="0x81420000"</p> <p>Description: Defined a mapping of the router with format "[range_start]", "[range_end]", "[outport_index]" where [range_start], [range_end] and [outport_index] are to be replaced with the initial address, end address (= range_start + range_size - 1) and the output port index respectively.</p>	<p>Type: parameter</p> <p>Data type: unisim::component::t1m2::interconnect: ↔:generic_router::Mapping</p>
<p>Name: mplb.mapping_8</p> <p>Default: range_start="0x81440000" ↔range_end="0x8144ffff" output_ ↔port="8" translation="0x81440000"</p> <p>Description: Defined a mapping of the router with format "[range_start]", "[range_end]", "[outport_index]" where [range_start], [range_end] and [outport_index] are to be replaced with the initial address, end address (= range_start + range_size - 1) and the output port index respectively.</p>	<p>Type: parameter</p> <p>Data type: unisim::component::t1m2::interconnect: ↔:generic_router::Mapping</p>
<p>profiler</p>	
<p>Name: profiler.min-data-read-prof- ↔addr</p> <p>Default: 0x00000000</p> <p>Description: Minimum address for data read profiling.</p>	<p>Type: parameter</p> <p>Data type: unsigned 32-bit integer</p>
<p>Name: profiler.max-data-read-prof- ↔addr</p> <p>Default: 0xffffffff</p> <p>Description: Maximum address for data read profiling.</p>	<p>Type: parameter</p> <p>Data type: unsigned 32-bit integer</p>

Name: profiler.min-data-write-prof- ↔addr Default: 0x00000000	Type: parameter Data type: unsigned 32-bit integer
Description: Minimum address for data write profiling.	
Name: profiler.max-data-write-prof- ↔addr Default: 0xffffffff	Type: parameter Data type: unsigned 32-bit integer
Description: Maximum address for data write profiling.	
Name: profiler.min-insn-fetch-prof- ↔addr Default: 0x00000000	Type: parameter Data type: unsigned 32-bit integer
Description: Minimum address for instruction fetch profiling.	
Name: profiler.max-insn-fetch-prof- ↔addr Default: 0xffffffff	Type: parameter Data type: unsigned 32-bit integer
Description: Maximum address for instruction fetch profiling.	
Name: profiler.min-insn-exec-prof- ↔addr Default: 0x00000000	Type: parameter Data type: unsigned 32-bit integer
Description: Minimum address for instruction execution profiling.	
Name: profiler.max-insn-exec-prof- ↔addr Default: 0xffffffff	Type: parameter Data type: unsigned 32-bit integer
Description: Maximum address for instruction execution profiling.	
Name: profiler.enable-data-read- ↔prof Default: false Valid: true, false	Type: parameter Data type: boolean

Description: Enable/Disable data read profiling.	
Name: profiler.enable-data-write- ↔prof	Type: parameter
Default: false	Data type: boolean
Valid: true, false	
Description: Enable/Disable data write profiling.	
Name: profiler.enable-insn-fetch- ↔prof	Type: parameter
Default: false	Data type: boolean
Valid: true, false	
Description: Enable/Disable instruction fetch profiling.	
Name: profiler.enable-insn-exec- ↔prof	Type: parameter
Default: false	Data type: boolean
Valid: true, false	
Description: Enable/Disable instruction execution profiling.	
Name: profiler.verbose	Type: parameter
Default: false	Data type: boolean
Valid: true, false	
Description: Enable/Disable verbosity.	
push-buttons-5bit	
Name: push-buttons-5bit.verbose	Type: parameter
Default: false	Data type: boolean
Valid: true, false	
Description: Enable/Disable verbosity.	
Name: push-buttons-5bit.polling- ↔period	Type: parameter
Default: 10 ms	Data type: sc_time
Description: Polling period of host keyboard.	
pwm-stub	
Name: pwm-stub.enable	Type: parameter
Default: true	Data type: boolean
Valid: true, false	

Description: Enable/Disable a lazy implementation of TLM 2.0 method interface.	
Name: pwm-stub.verbose Default: false Valid: true, false	Type: parameter Data type: boolean
Description: Enable/Disable verbosity.	
ram	
Name: ram.org Default: 0x0000000000000000	Type: parameter Data type: unsigned 64-bit integer
Description: memory origin/base address.	
Name: ram.bytesize Default: 268435456	Type: parameter Data type: unsigned 64-bit integer
Description: memory size in bytes.	
Name: ram.initial-byte-value Default: 0x00	Type: parameter Data type: unsigned 8-bit integer
Name: ram.cycle-time Default: 5 ns	Type: parameter Data type: sc_time
Description: memory cycle time.	
Name: ram.read-latency Default: 5 ns	Type: parameter Data type: sc_time
Description: memory read latency.	
Name: ram.write-latency Default: 0 s	Type: parameter Data type: sc_time
Description: memory write latency.	
Name: ram.verbose Default: false Valid: true, false	Type: parameter Data type: boolean

Description: enable/disable verbosity.	
splb0-stub	
Name: splb0-stub.enable Default: true Valid: true, false	Type: parameter Data type: boolean
Description: Enable/Disable a lazy implementation of TLM 2.0 method interface.	
Name: splb0-stub.verbose Default: false Valid: true, false	Type: parameter Data type: boolean
Description: Enable/Disable verbosity.	
splb1-stub	
Name: splb1-stub.enable Default: true Valid: true, false	Type: parameter Data type: boolean
Description: Enable/Disable a lazy implementation of TLM 2.0 method interface.	
Name: splb1-stub.verbose Default: false Valid: true, false	Type: parameter Data type: boolean
Description: Enable/Disable verbosity.	
timer	
Name: timer.verbose Default: false Valid: true, false	Type: parameter Data type: boolean
Description: Enable/Disable verbosity.	
Name: timer.c-baseaddr Default: 0x0000000083c00000	Type: parameter Data type: unsigned 64-bit integer
Description: Base address (C_BASEADDR design parameter).	
Name: timer.c-highaddr Default: 0x0000000083c0ffff	Type: parameter Data type: unsigned 64-bit integer
Description: High address (C_HIGHADDR design parameter).	

Name: timer.cycle-time	Type: parameter
Default: 5 ns	Data type: sc_time
Description: Cycle time.	
uart-lite	
Name: uart-lite.verbose	Type: parameter
Default: false	Data type: boolean
Valid: true, false	
Description: Enable/Disable verbosity.	
Name: uart-lite.c-baseaddr	Type: parameter
Default: 0x0000000084000000	Data type: unsigned 64-bit integer
Description: Base address (C_BASEADDR design parameter).	
Name: uart-lite.c-highaddr	Type: parameter
Default: 0x000000008400ffff	Data type: unsigned 64-bit integer
Description: High address (C_HIGHADDR design parameter).	
Name: uart-lite.cycle-time	Type: parameter
Default: 5 ns	Data type: sc_time
Description: Cycle time.	
Name: uart-lite.telnet-refresh-time	Type: parameter
Default: 10 ms	Data type: sc_time
Description: Telnet refresh time.	

A.6 Statistics

Simulation statistic counters are listed below:

bram	
Name: bram.memory-usage	Type: statistic
	Data type: unsigned 64-bit integer
Description: target memory usage in bytes (page granularity of 1048576 bytes).	
Name: bram.read-counter	Type: statistic
	Data type: unsigned 64-bit integer

Description: read access counter (not accurate when using SystemC TLM 2.0 DMI).	
Name: bram.write-counter	Type: statistic Data type: unsigned 64-bit integer
Description: write access counter (not accurate when using SystemC TLM 2.0 DMI).	
cpu	
Name: cpu.instruction-counter	Type: statistic Data type: unsigned 64-bit integer
Description: number of simulated instructions.	
Name: cpu.timer-cycle	Type: statistic Data type: unsigned 64-bit integer
Description: number of simulated timer cycles.	
Name: cpu.num-il1-accesses	Type: statistic Data type: unsigned 64-bit integer
Description: number of accesses to L1 instruction cache.	
Name: cpu.num-il1-misses	Type: statistic Data type: unsigned 64-bit integer
Description: number of misses to L1 instruction cache.	
Name: cpu.num-dl1-accesses	Type: statistic Data type: unsigned 64-bit integer
Description: number of accesses to L1 data cache.	
Name: cpu.num-dl1-misses	Type: statistic Data type: unsigned 64-bit integer
Description: number of misses to L1 data cache.	

Name: <code>cpu.num-itlb-accesses</code>	Type: statistic Data type: unsigned 64-bit integer
Description: number of accesses to shadow instruction translation look-aside buffer.	
Name: <code>cpu.num-itlb-misses</code>	Type: statistic Data type: unsigned 64-bit integer
Description: number of misses to shadow instruction translation look-aside buffer.	
Name: <code>cpu.num-dtlb-accesses</code>	Type: statistic Data type: unsigned 64-bit integer
Description: number of accesses to shadow data translation look-aside buffer.	
Name: <code>cpu.num-dtlb-misses</code>	Type: statistic Data type: unsigned 64-bit integer
Description: number of misses to shadow data translation look-aside buffer.	
Name: <code>cpu.num-utlb-accesses</code>	Type: statistic Data type: unsigned 64-bit integer
Description: number of accesses to unified data translation look-aside buffer.	
Name: <code>cpu.num-utlb-misses</code>	Type: statistic Data type: unsigned 64-bit integer
Description: number of misses to unified data translation look-aside buffer.	
Name: <code>cpu.num-interrupts</code>	Type: statistic Data type: unsigned 64-bit integer
Description: Number of interrupts.	
Name: <code>cpu.num-decrementer-interrupts</code>	Type: statistic Data type: unsigned 64-bit integer
Description: Number decrementer interrupts.	

<p>Name: <code>cpu.num-fixed-interval-timer-↔interrupts</code></p> <p>Type: statistic</p> <p>Data type: unsigned 64-bit integer</p> <p>Description: Number of fixed interval timer interrupts.</p>
<p>Name: <code>cpu.num-watchdog-timer-interrupts</code></p> <p>Type: statistic</p> <p>Data type: unsigned 64-bit integer</p> <p>Description: Number of watchdog timer interrupts.</p>
<p>Name: <code>cpu.num-debug-interrupts</code></p> <p>Type: statistic</p> <p>Data type: unsigned 64-bit integer</p> <p>Description: Number of debug interrupts.</p>
<p>Name: <code>cpu.num-external-input-interrupts</code></p> <p>Type: statistic</p> <p>Data type: unsigned 64-bit integer</p> <p>Description: Number of external input interrupts.</p>
<p>Name: <code>cpu.num-critical-input-interrupts</code></p> <p>Type: statistic</p> <p>Data type: unsigned 64-bit integer</p> <p>Description: Number of critical input interrupts.</p>
<p>Name: <code>cpu.num-machine-check-interrupts</code></p> <p>Type: statistic</p> <p>Data type: unsigned 64-bit integer</p> <p>Description: Number of machine check interrupts.</p>
<p>Name: <code>cpu.num-data-storage-interrupts</code></p> <p>Type: statistic</p> <p>Data type: unsigned 64-bit integer</p> <p>Description: Number of data storage interrupts.</p>
<p>Name: <code>cpu.num-instruction-storage-↔interrupts</code></p> <p>Type: statistic</p> <p>Data type: unsigned 64-bit integer</p>

Description: Number of instruction storage interrupts.	
Name: <code>cpu.num-data-tlb-error-interrupts</code>	Type: statistic Data type: unsigned 64-bit integer
Description: Number of data TLB error interrupts.	
Name: <code>cpu.num-instruction-tlb-error-interrupts</code>	Type: statistic Data type: unsigned 64-bit integer
Description: Number of instruction TLB error interrupts.	
Name: <code>cpu.num-alignment-interrupts</code>	Type: statistic Data type: unsigned 64-bit integer
Description: Number of alignment interrupts.	
Name: <code>cpu.num-program-interrupts</code>	Type: statistic Data type: unsigned 64-bit integer
Description: Number of program interrupts.	
Name: <code>cpu.num-system-call-interrupts</code>	Type: statistic Data type: unsigned 64-bit integer
Description: Number of system call interrupts.	
Name: <code>cpu.num-floating-point-unavailable-interrupts</code>	Type: statistic Data type: unsigned 64-bit integer
Description: Number of floating point unavailable interrupts.	
Name: <code>cpu.num-auxiliary-processor-unavailable-interrupts</code>	Type: statistic Data type: unsigned 64-bit integer
Description: Number of auxiliary processor unavailable interrupts.	

Name: cpu.run-time	Type: statistic Data type: sc_time
Description: run time.	
Name: cpu.idle-time	Type: statistic Data type: sc_time
Description: idle time.	
ram	
Name: ram.memory-usage	Type: statistic Data type: unsigned 64-bit integer
Description: target memory usage in bytes (page granularity of 1048576 bytes).	
Name: ram.read-counter	Type: statistic Data type: unsigned 64-bit integer
Description: read access counter (not accurate when using SystemC TLM 2.0 DMI).	
Name: ram.write-counter	Type: statistic Data type: unsigned 64-bit integer
Description: write access counter (not accurate when using SystemC TLM 2.0 DMI).	
timer	
Name: timer.num-tcr0-roll-over	Type: statistic Data type: unsigned 64-bit integer
Description: Number of timer/counter 0 roll over.	
Name: timer.num-tcr1-roll-over	Type: statistic Data type: unsigned 64-bit integer
Description: Number of timer/counter 1 roll over.	
Name: timer.num-timer0-generate- ↔interrupts	Type: statistic Data type: unsigned 64-bit integer

Description: Number of timer 0 generate interrupts.	
Name: timer.num-timer1-generate- ↔interrupts	Type: statistic Data type: unsigned 64-bit integer
Description: Number of timer 1 generate interrupts.	
Name: timer.num-timer0-generate- ↔interrupt-losses	Type: statistic Data type: unsigned 64-bit integer
Description: Number of timer 0 generate interrupt losses.	
Name: timer.num-timer1-generate- ↔interrupt-losses	Type: statistic Data type: unsigned 64-bit integer
Description: Number of timer 1 generate interrupt losses.	
Name: timer.num-timer0-captures	Type: statistic Data type: unsigned 64-bit integer
Description: Number of timer 0 captures.	
Name: timer.num-timer1-captures	Type: statistic Data type: unsigned 64-bit integer
Description: Number of timer 1 captures.	
Name: timer.num-timer0-old-capture- ↔losses	Type: statistic Data type: unsigned 64-bit integer
Description: Number of timer 0 old capture losses.	
Name: timer.num-timer1-old-capture- ↔losses	Type: statistic Data type: unsigned 64-bit integer

Description: Number of timer 1 old capture losses.	
Name: timer.num-timer0-new-capture- ↔losses	Type: statistic Data type: unsigned 64-bit integer
Description: Number of timer 0 new capture losses.	
Name: timer.num-timer1-new-capture- ↔losses	Type: statistic Data type: unsigned 64-bit integer
Description: Number of timer 1 new capture losses.	

A.7 Formulas

Simulation statistic formulas are listed below:

cpu		
Name: cpu.il1-miss-rate	Type: formula	
Formula: cpu.num-il1-misses / cpu. ↔num-il1-accesses	Data type: floating-point	double precision
Description: L1 instruction cache miss rate.		
Name: cpu.dl1-miss-rate	Type: formula	
Formula: cpu.num-dl1-misses / cpu. ↔num-dl1-accesses	Data type: floating-point	double precision
Description: L1 data cache miss rate.		
Name: cpu.itlb-miss-rate	Type: formula	
Formula: cpu.num-itlb-misses / cpu. ↔num-itlb-accesses	Data type: floating-point	double precision
Description: shadow instruction translation look-aside buffer miss rate.		
Name: cpu.dtlb-miss-rate	Type: formula	
Formula: cpu.num-dtlb-misses / cpu. ↔num-dtlb-accesses	Data type: floating-point	double precision
Description: shadow data translation look-aside buffer miss rate.		

<p>Name: <code>cpu.utlb-miss-rate</code></p> <p>Formula: <code>cpu.num-utlb-misses / cpu.↵num-utlb-accesses</code></p> <p>Description: unified data translation look-aside buffer miss rate.</p>	<p>Type: formula</p> <p>Data type: double precision floating-point</p>
<p>Name: <code>cpu.idle-rate</code></p> <p>Formula: <code>cpu.idle-time / cpu.run-↵time</code></p> <p>Description: idle rate.</p>	<p>Type: formula</p> <p>Data type: double precision floating-point</p>
<p>Name: <code>cpu.load-rate</code></p> <p>Formula: <code>1 - cpu.idle-time / cpu.↵run-time</code></p> <p>Description: load rate.</p>	<p>Type: formula</p> <p>Data type: double precision floating-point</p>
timer	
<p>Name: <code>timer.num-timer0-capture-losses</code></p> <p>Formula: <code>timer.num-timer0-old-capture-↵losses + timer.num-timer0-↵new-capture-losses</code></p> <p>Description: Number of timer 0 capture losses.</p>	<p>Type: formula</p> <p>Data type: signed 64-bit integer</p>
<p>Name: <code>timer.num-timer1-capture-losses</code></p> <p>Formula: <code>timer.num-timer1-old-capture-↵losses + timer.num-timer1-↵new-capture-losses</code></p> <p>Description: Number of timer 1 capture losses.</p>	<p>Type: formula</p> <p>Data type: signed 64-bit integer</p>

References

- [1] MiBench Version 1.0. <http://www.eecs.umich.edu/mibench>.
- [2] S-Record Output Format. 1992. In MC68000 Family Programmers Reference Manual, Appendix C, http://www.freescale.com/files/archives/doc/ref_manual/M68000PRM.pdf.
- [3] ELF-64 Object File Format. May 1998. <http://downloads.openwatcom.org/ftp/devel/docs/elf-64-gen.pdf>.
- [4] PPC440x5 CPU Core User's Manual. IBM, July 2003. [http://www-01.ibm.com/chips/techlib/techlib.nsf/techdocs/622DCFA1D98B1F10002575A7005464AF/\\$file/ppc440x5_um.pdf](http://www-01.ibm.com/chips/techlib/techlib.nsf/techdocs/622DCFA1D98B1F10002575A7005464AF/$file/ppc440x5_um.pdf).
- [5] DWARF Debugging Information Format Version 3. Free Standards Group, December 2005. <http://www.dwarfstd.org/doc/Dwarf3.pdf>.
- [6] S29GL-P MirrorBitTM Flash Family. SPANSION, November 2006. http://www.spansion.com/Support/Datasheets/S29GL-P_00_A13_e.pdf.
- [7] XPS General Purpose Input/Output (GPIO) (v2.00a). Xilinx, December 2009. DS569, http://www.xilinx.com/support/documentation/ip_documentation/xps_gpio.pdf.
- [8] XPS UART Lite (v1.01a). Xilinx, December 2009. DS571, http://www.xilinx.com/support/documentation/ip_documentation/xps_uartlite.pdf.
- [9] Embedded Processor Block in Virtex-5 FPGAs (v1.8) Reference Guide. Xilinx, February 2010. UG200, http://www.xilinx.com/support/documentation/user_guides/ug200.pdf.
- [10] LogiCORE IP XPS Interrupt Controller (v2.01a). Xilinx, April 2010. DS572, http://www.xilinx.com/support/documentation/ip_documentation/xps_intc.pdf.
- [11] LogiCORE IP XPS Timer/Counter (v1.02a). Xilinx, April 2010. DS573, http://www.xilinx.com/support/documentation/ip_documentation/xps_timer.pdf.
- [12] LogiCORE IP Virtex-5 APU Floating-Point Unit (v1.01a). Xilinx, March 2011. DS693, http://www.xilinx.com/support/documentation/ip_documentation/apu_fpu_virtex5.pdf.
- [13] M. R. Guthaus, J. S. Ringenberg, D. Ernst, T. M. Austin, T. Mudge, and R. B. Brown. Mibench: A free, commercially representative embedded benchmark suite. In Proceedings of the Workload Characterization, 2001. WWC-4. 2001 IEEE International Workshop, pages 3–14, Washington, DC, USA, 2001. IEEE Computer Society.
- [14] Richard Stallman, Roland Pesch, Stan Shebs, and al. Debugging with GDB. GNU. <http://sourceware.org/gdb/current/onlinedocs/gdb.pdf.gz>.